



www.serid.ait.ac.th/eric

## Solar Parabolic Trough Collector Hot Water System

A. Valan Arasu<sup>1</sup> and T. Sornakumar

**Abstract** – Several parabolic trough solar thermal systems have been built and operated throughout the world for different applications. In this paper, a complete description of a newly developed FRP solar parabolic trough collector (PTC) hot water generation system with a new embedded electronic controlled one axis solar tracking system is presented. The performance of the new PTC system and the new tracking system is evaluated and compared with the theoretical values. An economic analysis of the new PTC system in comparison with an existing conventional electric water heating system is carried out.

**Keywords** – Collector performance, life cycle cost, parabolic trough collectors, solar hot water generation, tracking mechanism.

### 1. INTRODUCTION

PTCs are the most mature solar technology to generate heat at temperatures up to 400°C for solar thermal electricity generation or process heat applications. The state-of-the art of this type of system is the Southern California power plants, known as solar electric generating systems (SEGS), which has a total installed capacity of 354 MWe [1]. Another important application of this type of collector is installed at Plataforma Solar de Almeria (PSA) in Southern Spain mainly for experimental purposes. The total installed capacity of the PTCs is equal to 1.2 MW [2]. Industrial Solar Technology (IST) Corporation erected several process heat installations in the United States with up to aperture area 2700 m<sup>2</sup> of this type of collector [3]. The recommendation of Bird *et al.* [4] is that the PTC concept should receive the highest priority for commercial development for low temperature (65-177°C) solar process heat applications. This paper presents performance and economic analysis of a newly developed solar FRP parabolic trough collector (PTC) hot water generation system with a new embedded electronic controlled one axis solar tracking system.

### 2. PARABOLIC TROUGH COLLECTORS

A parabolic trough collector, as shown in Figure 1, consists of a reflecting surface mounted on a reflector support structure having the profile of a parabola. A receiver assembly, comprising of a circular absorber tube with suitable selective coating and enclosed in a concentric glass envelope, is centered along the reflector focal line. With suitable end supports, the PTC module is supported on two end bearings mounted on two pylons. It is also provided with a precise driving system in order to track the sun and, thus, to maintain focusing of the solar radiation on the receiver assembly. The incident energy is

absorbed by the working fluid circulating through the absorber tube. PTCs are built in modules that are supported from the ground by simple pedestals at either end. PTCs are made by bending a sheet of reflective material into a parabolic shape. Based on environmental test data to date, mirrored glass appears to be the preferred mirror material although reflective materials with 5 to 7 years of life exists in the market [6]. The trough of the newly developed PTC is made of fibre glass and the method of fabrication of it is described in [7]. A recent development in this type of collectors is the design and manufacture of EuroTrough, a new PTC, in which an advanced lightweight structure is used to achieve cost efficient solar power generation [8]. The surface of the absorber or receiver tube is typically plated with selective coating that has a high absorptance for solar radiation, but a low emittance for thermal radiation loss [9], [10]. In the present work, the absorber tube surface is coated with heat resistant black paint of 0.9 absorptivity. A glass cover tube is usually placed around the receiver tube to reduce the convective heat loss from the receiver, thereby further reducing the heat loss coefficient. A disadvantage of the glass cover tube is that the reflected light from the concentrator must pass through the glass to reach the absorber, adding a transmittance loss of about 0.1, when the glass is clean. For maximum transmittance of insolation, glass of low iron content should be employed [11]. The glass envelope usually has an antireflective coating [12] to improve transmissivity. One way to further reduce convective heat loss from the receiver tube and thereby increase the performance of the collector, particularly for high temperature applications, is to evacuate the space between the glass cover tube and the receiver [13]. The design of a PTC system has been accomplished by performing an optimization of the collector's aperture and rim angle and the selection of receiver's diameter [14]. Design of other aspects of the collector is given in [15]–[16]. The design and simulation analysis of a PTC hot water generation system has been accomplished by the authors [17].

Department of Mechanical Engineering, Thiagarajar College of Engineering, Madurai-15, India.

<sup>1</sup> Corresponding author;  
E-mail: [avamech@tce.edu](mailto:avamech@tce.edu)

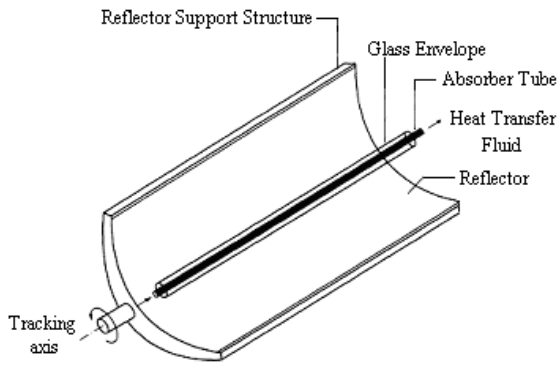

Fig. 1. Parabolic Trough Collector

3. PARABOLIC TROUGH COLLECTORS

In the present work, a new parabolic trough collector system, which has been developed for hot water generation, is presented in Figure 2. The PTC system for hot water generation includes a PTC, a hot water storage tank (HWST) of well-mixed type and a circulating pump. The parabola of the present collector with a rim angle of 90° is very accurately constructed of fiberglass [7]. A flexible solar reflector material from Clear Dome Solar, San Diego (SOLARFLEX foil) with a reflectance of 0.974 [18] is used in the present work. The solar receiver consists of a copper tube, a glass envelope and rubber cork seals at both ends of the glass envelope. The copper tube is coated with a heat resistant black paint and is surrounded by a concentric glass cover with an annular gap of 0.5 cm. The rubber corks are incorporated to achieve an air-tight enclosure. Water from the storage tank is pumped through copper tube, where it is heated and then flows back into the storage tank. It is assumed that the water in the storage tank is always well mixed and consequently is at a uniform temperature,  $T_1$ , which varies only with time. The PTC rotates around the horizontal north/south axis to track the Sun from east to west as it moves through the sky during the day. The specifications of the PTC system are detailed in Table 1.

Table 1. PTC Hot water system specifications

Items	Value
Collector Aperture	0.8 m
Collector Length	1.25 m
Rim Angle	90°
Focal Distance	0.2 m
Receiver Diameter	12.8 mm
Glass Envelope Diameter	22.6 mm
Concentration Ratio	19.89
Water Flow Rate	1.0 lpm
Storage Tank Capacity	35 liters
Tank Material	Stainless Steel
Tank Insulation Material	Glass Wool

4. TRACKING MECHANISM

Because of the presence of an optical system, a parabolic trough collector usually has to follow or track the sun so that the beam radiation is directed onto the receiver tube and the collectors operate at its optimum [19]. Parabolic trough collectors require single axis tracking of the sun. The collector can be orientated in an east–west direction, tracking the sun from north to south, or orientated in a north–south direction and tracking the sun from east to west. Over the period of one year, a horizontal north–south trough field usually collects slightly more energy than a horizontal east–west one. However, the north–south field collects a lot of energy in summer and much less in winter. The east–west field collects more energy in the winter than a north–south field and less in summer, providing a more constant annual output. Therefore, the choice of orientation usually depends on the application and whether more energy is needed during summer or during winter [20]. A tracking mechanism must be reliable and able to follow the sun with a certain degree of accuracy, return the collector to its original position at the end of the day or during the night, and also track during periods of intermittent cloud cover. Additionally, tracking mechanisms are used for the protection of collectors, i.e. they turn the collector out of focus to protect it from the hazardous environmental and working conditions, like wind gust, overheating and failure of the thermal fluid flow mechanism. The required accuracy of the tracking mechanism depends on the collector acceptance angle [21]. Various forms of tracking mechanisms, varying from complex to very simple, have been proposed. They can be divided into two broad categories, namely mechanical [22]-[24] and electrical/electronic systems. The electronic systems generally exhibit improved reliability and tracking accuracy. The electronic systems can be further subdivided into the following: i) mechanisms employing motors controlled electronically through sensors, which detect the magnitude of the solar illumination [25]-[28] and ii) mechanisms using computer controlled motors with feedback control provided from sensors measuring the solar flux on the receiver [29]-[31].

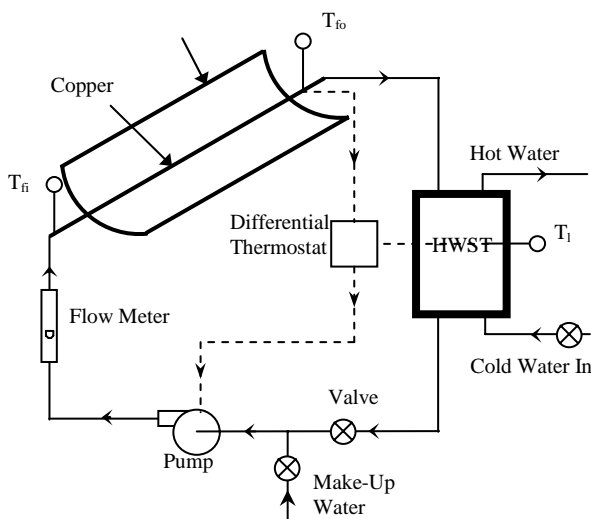

Fig. 2. PTC Hot Water System

A tracking mechanism (Figure 3) developed by the authors [32] uses three light dependent resistors which detect the focus, sun/cloud, and day or night conditions and give instruction to a DC motor through an embedded electronic control system to focus the collector, to follow approximately the sun path when cloudy conditions exist and return the collector to the east during night. The

position of Sun is successfully detected using light dependent resistors, with an accuracy of  $0.1^\circ$ . The accuracy is much greater than the required  $0.5^\circ$ , which is determined from the collector acceptance angle test.

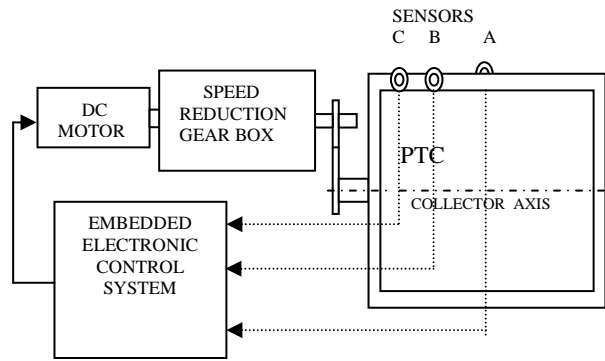

Fig. 3. PTC – Tracking system

**Collector Acceptance Angle Test**

Since collector acceptance angle characterizes the effect of errors in the angular orientation of the tracking mechanism, a test to determine the collector acceptance angle is carried out according to ASHRAE standard 93-1986 [21]. With the tracking mechanism disengaged, the collector efficiency is determined at various out of focus angles as the Sun travels over the collector’s plane.

The angle of incidence measured from the normal to the tracking axis is plotted against the efficiency factor. The efficiency factor is computed as the ratio of thermal efficiency at a particular out of focus angle to the maximum thermal efficiency at normal incidence. The collector acceptance angle is defined as the range of incidence angles measured from the normal to the tracking axis in which the efficiency factor varies by not more than 2% from the normal incidence angle [21]. Therefore from Figure 4, the collector half-acceptance angle, is  $0.5^\circ$ . This angle determines the maximum error of the tracking mechanism.

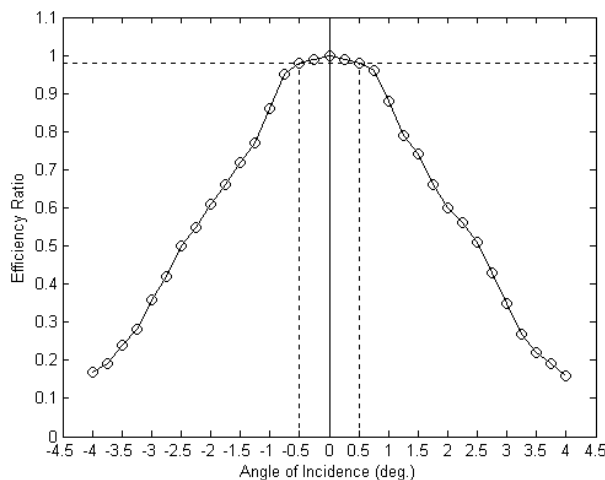

Fig. 4. Collector acceptance angle

**5. OPTICAL AND THERMAL PERFORMANCE OF PTC**

The parabolic trough collector dimensions are shown in

Figure 5. The concentration, also called as geometric concentration or area concentration, is defined as ratio of absorber area to receiver area.

$$C = \frac{A_a}{A_r} = \frac{2\Pi r_r L}{WL} \tag{1}$$

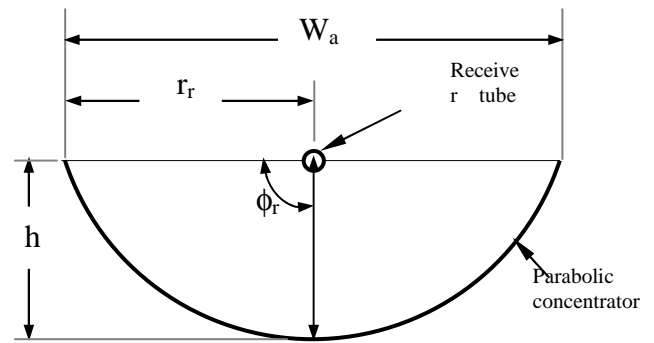

Fig. 5. Parabolic trough collector dimensions

Closely related to the concentration is the acceptance angle ( $2\theta_c$ ), that is, the angular range over which all or almost all rays are accepted without moving all or part of the collector.

The concentration ratio achievable in practical systems is [33]:

$$C = \frac{2\left(\frac{W}{2}\right)}{2\Pi r_r} = \frac{\sin \phi_r}{\Pi \sin \theta_c} = \frac{\sin \phi_r}{\Pi} C_{ideal} \tag{2}$$

where  $C_{ideal}$  is the theoretical limit of concentration ( $= 1/\sin \theta_c$ ) and  $\phi_r$  is the collector rim angle. The collector rim angle ( $\phi_r$ ) is defined as the angle subtended by the edges of the reflector at the focus. The maximum occurs at  $\phi_r = 90^\circ$  and falls  $\Pi$  short of the ideal limit. All practical collectors reach only one-fourth to one-half of the thermodynamic concentration limit. The new PTC has concentration ratio of 19.89 and an acceptance angle of  $1^\circ$ .

One measure of the performance of a PTC is the optical efficiency ( $\eta_o$ ), defined as the ratio of the energy absorbed by the receiver to the energy incident on the concentrator’s aperture [34]. It is expressed as [14]:

$$\eta_o = \rho_m \tau_e \alpha_r \gamma \left[ (1 - A_f \tan \theta) \cos \theta \right] \tag{3}$$

where  $\rho_m$  is reflector reflectance,  $\tau_e$  is transmittance of glass cover,  $\alpha_r$  is receiver absorptivity,  $\gamma$  is intercept factor and  $\theta$  is angle of incidence. The optical efficiency,  $\eta_o$  of the new FRP PTC was evaluated as 0.694.

The most complex parameter involved in determining the optical efficiency of a PTC is the intercept factor,  $\gamma$ . It is defined as the ratio of the energy intercepted by the receiver to the energy reflected by the focusing device [34]. The value of intercept factor depends on the size of the receiver, the surface angle errors of the parabolic mirror and solar beam spread. For the evaluation of the intercept factor  $\gamma$ , a closed-form

expression developed by Guven and Bannerot [35] is used:

$$\gamma = \frac{1 + \cos \phi_r}{2 \sin \phi_r} \int_0^{\phi_r} \text{Erf} \left( \frac{\sin \phi_r (1 + \cos \phi) (1 - 2d^* \sin \phi) - (\pi \beta^* (1 + \cos \phi_r))}{\sqrt{2\pi \sigma^* (1 + \cos \phi_r)}} \right) - \text{Erf} \left( \frac{\sin \phi_r (1 + \cos \phi) (1 + 2d^* \sin \phi) + (\pi \beta^* (1 + \cos \phi_r))}{\sqrt{2\pi \sigma^* (1 + \cos \phi_r)}} \right) \frac{d\phi}{(1 + \cos \phi)} \quad (4)$$

where  $d^*$  is universal nonrandom error parameter due to receiver dislocation and reflector profile errors,  $\beta^*$  is universal nonrandom error parameter due to angular errors and  $\sigma^*$  is universal random error parameter. A simple MATLAB program, which numerically evaluates the above expression, is presented in [17].

Thermal efficiency ( $\eta$ ) of a PTC is defined as the rate at which useful energy ( $Q_u$ ) is delivered to the working fluid per unit of aperture area divided by the beam solar flux ( $I$ ) at the collector's aperture plane. The thermal efficiency  $\eta$  may be calculated from an energy balance on the receiver [34], [36], which is given by:

$$\eta = \frac{Q_u}{I A_a} = \frac{\eta_o I A_a - U_L (T_r - T_a) A_r}{I A_a} = \eta_o - \left( \frac{U_L (T_r - T_a)}{I \times C} \right) = \frac{m c_p (T_{fo} - T_{fi})}{I A_a} \quad (5)$$

The thermal efficiency of a concentrating collector operating under steady state conditions can be described by ASHRAE 1986 [21]:

$$\eta = F_R \eta_o - \frac{F_R U_L}{C} \left( \frac{T_{fi} - T_a}{I} \right) \quad (6)$$

The thermal efficiency from Equation 6 is plotted against  $(T_{fi} - T_a)/I$ , a straight line will result provided  $U_L$  is constant. The intercept is  $F_R \eta_o$  and the slope is  $F_R U_L / C$ .

The theoretical and experimental performance curves of the new PTC, located in Madurai (Latitude  $9^\circ 50'$  and Longitude  $78^\circ 10'$ ), as derived from a series of tests carried out according to ASHRAE standard 93 (1986) [21] on the new solar PTC hot water system on seven days [37], and the other from the simulation program [17] are shown in Figure 6. An equation for the experimental curve is obtained using the standard technique of a least squares fit as given below.

$$\eta = 0.6905 - 0.3865 \left( \frac{\Delta T}{I} \right) \quad (7)$$

There is a minor difference between the theoretical and the experimental results with respect to the test slope (5.92 %) and a moderate difference is for the test intercept (9.37 %).

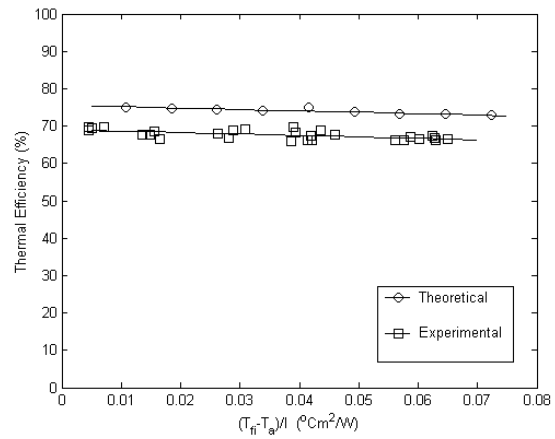

Fig. 6. Thermal efficiency curves

A simulation model based on MATLAB program is developed to determine the hourly storage tank water temperature. For the estimation of hourly storage tank water temperature, the following equation is used.

$$T_{l,new} = T_{l,old} + \frac{[Q_u - Q_l - (UA)_t (T_{l,old} - T_a)]}{[(\rho V C_p)_l + (\rho V C_p)_t]} \Delta t \quad (8)$$

where  $(UA)_t$  the product of the overall heat transfer coefficient between the tank water and the ambient air and surface area of the tank and  $(\rho V C_p)_l$  represents the heat capacity of the water in the tank,  $(\rho V C_p)_t$  the heat capacity of the tank material. In the present work,  $Q_l$  is taken as zero and  $\Delta t = 1$  hour. The variation of the storage tank water temperature values with respect to time for a sunny day is presented in Figure 7. The storage tank water temperature, both predicted ( $T_{l, sim}$ ) and experimental data ( $T_{l, exp}$ ), increase steadily with the collection time as no energy is withdrawn from the tank to the load during the collection period. The difference between the predicted ( $T_{l, sim}$ ) and the actual storage tank temperature ( $T_{l, exp}$ ) is reasonably small.

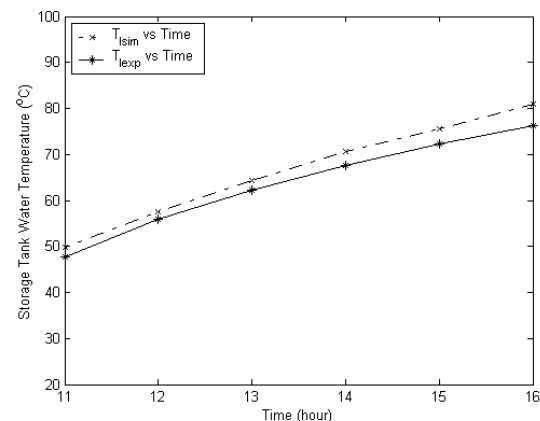

Fig. 7. Storage tank temperature variation with time

## 6. ECONOMIC EVALUATION OF PTC SOLAR HOT WATER SYSTEM

The method employed, in the present work, for the economic analysis of solar PTC hot water system is called the Life cycle cost. Life Cycle Cost (LCC) is the sum of all the costs associated with a solar thermal energy system over its lifetime in terms of money value at the present instant of time and takes into account the time value of money.

In order to evaluate the economic viability of a solar system, one has to calculate the savings or cost, which will accumulate annually and on a long term basis as a result of installing the solar system. On annual basis, the solar system would help in saving conventional energy in the form of fuel or electricity. The annual cost (AC) such as annual fuel cost savings (AFS), annual maintenance cost (AMC), annual electricity cost (AEC), and annual tax savings (ATS) in any year  $N$  is estimated using the following equation with an appropriate first year cost (FYC) and interest rate (IR).

$$AC = FYC(1 + IR)^{N-1} \quad (9)$$

The mortgage payment is the annual value of money required to cover the funds borrowed at the beginning to install the system. This includes interest and principal payment. Assume that the solar system requires a total initial cost (IC) of which either full or a fraction is taken as mortgage (MA). The estimation of the annual mortgage payment (AMP) can be found by dividing the amount borrowed by the present worth factor (PWF) [38]. The present worth factor in any year  $N$  is:

$$PWF = \frac{(1 + MIR)^N - 1}{MIR(1 + MIR)^N} \quad (10)$$

where MIR is the mortgage interest rate, which varies from country to country.

Thus the annual solar savings (ASS) is:

$$ASS = AFS - AMP - AMC - AEC + ATS \quad (11)$$

The present worth of annual solar savings (PWASS), for the annual market discount rate is MDR, in any year  $N$  is [38]:

$$PWASS = \frac{ASS}{(1 + MDR)^N} \quad (12)$$

The life cycle solar savings over life time (LT) of a system is the sum of present worth of annual solar savings over the period plus the present worth of resale value at the end of its lifetime minus the initial down payment (DP) made at the time of installation of the solar system [11]. Thus,

$$LCS = \sum_{N=1}^{LT} PWASS(N) + PWRS - DP \quad (13)$$

where the present worth of resale value (PWRS) is given by [39]:

$$PWRS = \frac{RS}{(1 + MDR)^{LT}} \quad (14)$$

The initial cost (IC) of the new PTC hot water generation system is Rs. 25,000/-. One US\$ is about 43.62 Indian Rupees (Rs.) as on August 2005. The heater of the existing electric water heating system is on for about thirty minutes until the water in the tank attains a sufficient temperature so as to keep the dish warm. The average hot water temperature was measured as 65 °C. The heater is turned on at regular intervals over the canteen working hours of 8 hours and is observed to be consuming 5 kWh in a day. At the tariff of Rs. 5.8/- per kWh, the cost of electricity is Rs. 29.0/- per day. The heater is in use for 275 days in a year. So the annual electricity cost for the electric heater is Rs. 8 000/-. The LCS of the new FRP PTC hot water generation system, replacing an existing electric water heating system is evaluated taking the mortgage interest rate (MIR) as 12.5 %, annual market discount rate (MDR) as 8 % and the optimal operation life time (LT) as 15 years. The life cycle solar savings (LCS) increases rapidly and becomes positive at the end of six years because of the electrical energy cost savings and attains the value of Rs. 23171.66/- after 15 years, which is a significant saving. Thus, the new solar PTC hot water generation system is more economic than the existing electric water heating system.

## 7. CONCLUSION

In this paper, a complete description of a newly developed FRP solar parabolic trough collector hot water generation system with a new embedded electronic controlled one axis tracking system is presented. The performance of the PTC system and the tracking system is evaluated and compared with the theoretical values. The small difference between the predicted and experimental values demonstrates that the design procedure followed is correct and therefore the simulation model can be used for long term prediction of parabolic trough collector hot water generation system performance. An economic analysis of the new PTC system based on LCC method replacing an existing conventional electric water heating system is carried out. The new FRP based solar PTC hot water generation system is found to be more economic than the electric water heating system.

## NOMENCLATURE

$A_a$	Collector aperture area (m <sup>2</sup> )
$A_f$	Geometric factor (m <sup>2</sup> )
$A_r$	Receiver tube area (m <sup>2</sup> )
$C$	Concentration ratio
$c_p$	Specific heat capacity of water (J/kg-K)
$D_{r,o}$	Receiver tube outer diameter (m)
$dr$	Receiver dislocation distance (mm)
$d^*$	Universal nonrandom error parameter due to receiver dislocation and reflector profile errors [ $d^* = dr/D_{r,o}$ ]

$F_R$	Heat removal factor
$f$	Focal distance (m)
$h_p$	Parabola height (m)
$I$	Direct solar radiation ( $W/m^2$ )
$L$	Collector length (m)
$\dot{m}$	Mass flow rate (kg/s)
$Q_u$	Useful energy (W)
$Q_l$	Rate of energy discharge to the load (W)
$r_r$	Rim radius (m)
$T_a$	Ambient air temperature (K)
$T_{fi}$	Water inlet temperature (K)
$T_{fo}$	Water outlet temperature (K)
$T_{l,new}$	New storage tank water temperature (K)
$T_{l,old}$	Old storage tank water temperature (K)
$T_r$	Mean receiver surface temperature (K)
$U_L$	Overall heat loss co-efficient ( $W/m^2K$ )
$W$	Aperture width (m)

**Greek**

$\alpha_r$	Receiver absorptivity
$\beta$	Misalignment angle error (degree)
$\beta^*$	Universal nonrandom error parameter due to angular errors [ $\beta^* = \beta C$ ]
$\phi_r$	Collector rim angle (degree)
$\gamma$	Intercept factor
$\eta$	Thermal efficiency
$\eta_o$	Optical efficiency
$\theta$	Angle of incidence (degree)
$\theta_c$	Acceptance half-angle (degree)
$\rho_m$	Mirror (or) reflector reflectance
$\sigma$	Total reflected-energy standard deviations at normal incidence
$\sigma^*$	Universal random error parameter [ $\sigma^* = \sigma C$ ]
$\tau_e$	Transmittance of glass cover

**Abbreviations**

AC	Annual Cost in Rupees
AEC	Annual Electricity Cost in Rupees
AFS	Annual Fuel Cost Savings in Rupees
AMC	Annual Maintenance Cost in Rupees
AMP	Annual Mortgage Payment in Rupees
ASS	Annual Solar Savings in Rupees
ATS	Annual Tax savings in Rupees
FYC	First Year Cost in Rupees
IC	Initial Cost in Rupees
IR	Interest Rate
LCC	Life Cycle Cost
LCS	Life Cycle Savings in Rupees
LT	Life Time of the system in Years
MA	Mortgage Amount in Rupees
MDR	Market Discount Rate in percentage
MIR	Mortgage Interest Rate in percentage

MP	Mortgage Period in Years
N	Operation life of the system under consideration in Year
PTC	Parabolic Trough Collector
PWF	Present Worth Factor
PWASS	Present Worth of Annual Solar Savings in Rupees
PWSV	Present Worth of Salvage Value in Rupees
RS	Resale Value in Rupees

**REFERENCES**

- [1] Kearney, DW, and Price HW. 1992. Solar thermal plants-LUZ concept (current status of the SEGS plants). In *Proceedings of the Second Renewable Energy Congress*, Reading UK, 2: 582–588.
- [2] Grasse, W. Solar PACES Annual Report, DLR Germany; 1995.
- [3] Kruger, D., Heller, A., Hennecke, K., Duer K. 2000. Parabolic trough collectors for district heating systems at high latitudes: a case study. In *Proceedings of Eurosun'2000* on CD ROM, Copenhagen, Denmark.
- [4] Bird, S.P, and Drost, M.K. 1982. Assessment of generic solar thermal concept for large industrial process heat applications. In *Proceedings of the ASME Solar Energy Division, Fourth Annual Conference*, Albuquerque, New Mexico.
- [5] Kutscher, C.F. 1981. Design considerations for solar industrial process heat systems. SERI/TR-632-783, Solar Energy Research Institute, Golden, Colorado.
- [6] Harrison, J. 2001. Investigation of reflective materials for the solar cooker. Florida Solar Energy Center, 24 December.
- [7] Valan Arasu, A., and Sornakumar, T. 2007. Design, manufacture and testing of fiberglass reinforced parabola trough for parabolic trough solar collectors. *Solar Energy* 81 (10):1273-1279.
- [8] Lupfert, E., Geyer, M., Schiel, W., Zarza, E., Gonzalez-Anguilar, R.O., Nava, P. 2000. Eurotrough: a new parabolic trough collector with advanced light weight structure. In *Proceedings of Solar Thermal 2000 International Conference* on CD-ROM, Sydney, Australia.
- [9] John, S., Nagarani, N., and Rajendran, S. 1991. Black cobalt solar absorber coatings. *Solar Energy Materials* 22: 293-302.
- [10] Wackelgard, E. 1998. Characterization of black nickel solar absorber coatings electroplated in a nickel chlorine aqueous solution. *Solar Energy Material & Solar Cells* 56: 35-44.
- [11] Sukhatme, S.P. 1999. *Solar Energy – Principles of thermal collection and storage- Second Edition*. New Delhi: Tata McGraw-Hill Publishing Company Limited.
- [12] Chow, S.P., and Harding, G.L.. 1985. Effect of antireflection coatings on the transmittance of glass tubular and plane double glazed covers for flat plate solar collectors. *Solar Energy* 34 (2):183-186.
- [13] Gee, R.C., and Murphy, L.M. 1983. An economic and performance evaluation of parabolic trough component improvements. *Journal of Solar Energy*

- Engineering* 105: 10-18.
- [14] Kalogirou, S., Eleftheriou, P., Lloyd, S., and Ward, J. 1994. Design and performance characteristics of a parabolic-trough solar collector system. *Applied Energy* 47: 341-54.
- [15] Bakos, G.C., Adamopoulos, D., Tsagas, N.F., and Soursos, M. 1999. Design and construction of a line-focus parabolic trough solar concentrator for electricity generation. In *Proceedings of ISES Solar World Congress* on CD-ROM, Jerusalem, Israel.
- [16] Kalogirou, S. 1996. Parabolic trough collector system for low temperature steam generation: design and performance characteristics. *Applied Energy* 55 (1):1-19.
- [17] Valan Arasu, A.; and Sornakumar, T. 2005. Design and simulation analysis of a parabolic trough solar collector hot water generation system. *International Energy Journal* 6(2): 13-25.
- [18] ClearDome Solar Systems Heating and Cooking Products, San Diego, USA. Accessed at [www.cleardomesolar.com](http://www.cleardomesolar.com). 2003.
- [19] Cope, A.W.G., and Tully, N. 1981. Simple tracking strategies for solar concentrators. *Solar Energy* 27(5): 361-365.
- [20] Kalogirou, S. 1991. Solar energy utilisation using parabolic trough collectors in Cyprus. MPhil Thesis. The Polytechnic of Wales.
- [21] ASHRAE Standard 93. 1986. Method of testing to determine the thermal performance of solar collectors. American Society of Heating, Refrigerating and Air-Conditioning Engineers, Atlanta, GA.
- [22] Gupta, K.C., Mirakhur, P.K., and Sathe, A.P. 1978. A simple solar tracking system. SUN. In *Proceedings of the International Solar Energy Society*, New Delhi, India: Pergamon Press.
- [23] Cope, N.A., Ingleby, H.A., Farber, E.A., and Morrison, C.A. 1981. Dynamic response analysis of a solar powered heliotropic fluid mechanical drive system. University of Florida.
- [24] Singh, T.A.K., and Dinesh, P.S. 2001. Liquid vapour balance based sun tracking system. In *Proceedings of the 25th National Renewable Energy Convention 2001 of the Solar Society of India*, Warangal, India: 401-406.
- [25] Hession, P.J., and Bonwick, W.J. 1984. Experience with a Sun tracker system. *Solar Energy* 32:3-11.
- [26] Zogbi, R., and Laplaze, D. 1984. Design and construction of a Sun tracker. *Solar Energy* 33: 369-72.
- [27] Mori, Y., Hijikata, K., and Himero, N. 1977. Fundamental research on heat transfer performances of solar focusing and tracking collector. *Solar Energy* 19: 595-600.
- [28] Kalogirou, S. 1996. Design and construction of a one-axis Sun tracking mechanism. *Solar Energy* 57 (6): 465-469.
- [29] Boultinghouse, K.D. 1982. Development of a solar flux tracker for parabolic trough collectors. Albuquerque, USA: Sandia National Labs.
- [30] Briggs, F. 1980. Tracking-refinement modelling for solar-collector control. Albuquerque, USA: Sandia National Labs.
- [31] Nuwayhid, R.Y., Mrad, I., and Abu-Said, R. 2001. The realisation of a simple solar tracking concentrator for university research applications. *Renewable Energy* 24: 207-222.
- [32] Valan Arasu, A., and Sornakumar, T. 2007. Design, development and performance studies of embedded electronic controlled one axis solar tracking system. *Asian Journal of Control* 9 (2): In Press.
- [33] Dickinson, W.C. and Cheremisinoff, P.N. 1980. *Solar Energy Technology Handbook – Part A, Engineering Fundamentals*. New York: Marcel Dekker Inc.
- [34] Duffie, J.A., and Beckman, W.A. 1991. *Solar Engineering of Thermal Processes- 2<sup>nd</sup> edition*. New York: John Wiley.
- [35] Guven, H.M. and Bannerot, R.B. 1985. Derivation of universal error parameters for comprehensive optical analysis of parabolic troughs. In *Proceedings of the ASME-ASES Solar Energy Conference*. Knoxville, USA: 168-174.
- [36] Kreith, F. and Kreider, J.F. 1978. *Principles of Solar Engineering*. New York: McGraw-Hill.
- [37] Valan Arasu, A.; and Sornakumar, T. 2006. Performance characteristics of parabolic trough solar collector system for hot water generation. *International Energy Journal* 7 (2): 137-145.
- [38] Stoecker, W.F. 1989. *Design of Thermal Systems- 3<sup>rd</sup> Edition*. Singapore: McGraw-Hill.
- [39] Crawford, R.H., Treloar, G.J. 2004. Net energy analysis of solar conventional domestic hot water systems in Melbourne, Australia. *Solar Energy*, 76: 159-63.

