

Cyclic Flow Reversal Combustion in Porous Media

Sumrerng Jugjai, Winai Tulsomkid,
Apiwat Hongdamnern and Akarathon Sereechaikul

Combustion and Engine Research Laboratory (CERL),
Department of Mechanical Engineering,
King Mongkut's University of Technology Thonburi,
Sukswas 48, Bangkok 10140,
THAILAND

ABSTRACT

An experimental study of combustion in a porous medium, with and without a cyclic flow reversal of a mixture through the porous medium, was performed. The thermal structure, in terms of axial temperature distribution, of two systems (with and without cyclic flow reversal of the mixture) is compared so as to elucidate the performance of the two systems. The effect of dominating parameters, i.e., half-period, equivalence ratio and flow velocity of the gas mixture on the axial temperature distribution is reported. It is shown that the transient behavior of the thermal capacity of the porous medium, induced by a cyclic flow reversal of the mixture, plays a vital role in yielding a higher quality combustion flame than without a cyclic flow reversal system or a one-way flow combustion system. The half-period of the cyclic flow reversal of the mixture has a moderate effect on the maximum flame temperature. Equivalence ratio and flow velocity have a similar effect on the thermal structure with respect to an increase in the maximum temperature and in the time averaged exhaust temperature, leading to an increase in heat losses. In this study, the minimum heat content of the mixture that would be able to burn by the CFRC system is 140 kJ/kg at a minimum equivalence ratio of $\Phi = 0.046$, a flow velocity of about 0.2 m/s and a half period of 30 seconds. The corresponding adiabatic flame temperature of the equivalence ratio of $\Phi = 0.046$ is 177 °C.

1. INTRODUCTION

Based on a conventional one-way flow combustion (hereafter referred to as OWFC), several versions of combustion that can produce the so-called "excess enthalpy flame" were proposed in the past [1, 2]. These versions range from the single gaseous phase combustion equipped with a convective heat exchanger to the multiphase (solid phase and gaseous phase) combustion in an inert porous medium [3, 4, 5]. These combustion techniques are able to create an internal recirculation or a recuperation of heat from the burned downstream gases to the unburned mixture upstream of the reaction zone by convection and thermal radiation. This results in an excess enthalpy flame which has a peak temperature higher than the adiabatic flame temperature of the mixture. Moreover, favorable flammability limits and combustion stability were also obtained which are very suitable for the lean combustion of extreme dilutions of the mixture with air, such as volatile organic compounds (VOCs) from industries [6].

Until recently, cyclic flow reversal combustion in porous media (hereafter referred to as CFRC) was introduced by Swedish engineers [7] and was subsequently studied by theoretical consideration and also by experiment. Results of the theoretical studies [8] show that a maximum flame temperature of 13 orders higher than the theoretical one was claimed in the studies which depended almost solely on the reaction rate constant (activation energy and the frequency factor). Parameters other than the reaction rate constant have a strong effect on the location of the reaction zone. Hoffmann, et al. [9] conducted further numerical analysis on reciprocating super adiabatic combustion in a porous medium. The formation of the dominating heat pattern of the porous body, i.e., the development of convective and radiative heat losses during one half-cycle and the related heat storage and heat release were clarified. However, only theoretical works [8, 9] were considered in the past and they are lacking a direct comparison between the OWFC and the CFRC so that the relative merits of one system over the other can be judged on the basis of using the same operating conditions of the two systems, rather than considering each system independently.

The aim of the study is to present results of an experimental study of both the CFRC system and the OWFC system. Comparison in performance between the two systems was conducted so as to further understand the combustion regime and the heat transfer characteristics of the self-sustained combustion flame of the typical gaseous mixture. The effects of various parameters (such as half-period, flow velocity and equivalence ratio), that are expected to control the combustion phenomena, on the thermal structure of the CFRC are clarified. The results will also be used to support numerical results so as to validate the theoretical model proposed in the near future.

2. EXPERIMENTAL APPARATUS AND PROCEDURES

Figure 1 shows the experimental apparatus which can be used to study both the CFRC system and the OWFC system. It consists of two main components: a combustor and an alternating valve set. The combustor, which lies in a horizontal position, is stainless steel pipe 76 mm (3 in) in diameter and 210 mm in length. It is filled with porous medium *A* and porous medium *B*, which is located at both ends of the porous medium *A* for the purpose of reinforcement. The porous medium *A* is comprised of a stack of porous ceramic inside the pipe. The ceramic has 6 pores per cm (ppcm) and is 15 mm thick and 50 mm in diameter. The component of the ceramic is magnesia-stabilized zirconia having porosity of about 85%. Porous medium *B* is made from stainless steel netting, the mesh size of which is 16 meshes per inch. To form the porous medium *B*, a number of stainless steel net layers are packaged together with a geometrical thickness of 10 mm.

The alternating valve set consists of an alternating valve rotor, an alternating valve housing and an AC motor with a reciprocating cam mechanism. Both the rotor and the housing are made from carbon steel. The rotor is a solid cylinder with diameter of 75 mm. It has two drilled holes with diameters of 25 mm which are parallel to each other but perpendicular to the axis of the rotor. The circumference surface of the rotor is precisely ground so as to exactly fit to the housing recess and therefore the gaseous mixture is prevented from leaking through the gap between the rotor and the housing. The rotor is alternating back and forth by a mechanical device comprised of an AC motor and a reciprocating cam mechanism to change the flow direction of the mixture. The time interval (or half-period) for each flow direction can be independently adjusted from 2 to 60 seconds by a separate time switch and limit switch.

Type *K* sheath thermocouples of diameter 1.5 mm were used in the experiment at all measuring locations along the axial direction of the combustor, as shown in Fig. 1. T_1 and T_9 indicate the gas temperature at about 40 mm from both ends of the combustor, whereas T_2 to T_8 indicate the solid phase

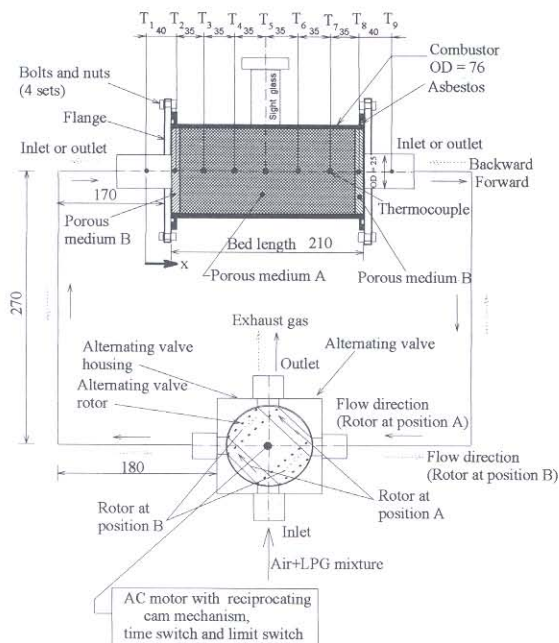

Fig. 1. Experimental apparatus for the CFRC system and the OWFC system.

temperatures inside the combustor. Each of these thermocouples is connected to a digital thermometer and a data acquisition system, which consists of data logger and computer software for recording the temperatures. Liquefied petroleum gas (LPG) diluted with air was used as a typical fuel in the experiment. The composition of the LPG was propane (C_3H_8) 40% (by vol.) and butane (C_4H_{10}) 60%, respectively, with a low heating value of about 115 MJ/m^3 (normal). An air blower was used for supplying the combustion air to mix with the LPG prior to entering the alternating valve. Both the combustion air and the LPG were metered by calibrated rotameters.

The OWFC system was started before switching to the CFRC system. The position of the alternating valve rotor was fixed at either position A (forward flow) or position B (backward flow) so as to allow the mixture with an appropriate initial equivalence ratio Φ (ratio of a theoretical air to a practical air) of about 0.8 to flow through porous medium A, i.e., OWFC system. The initial flow rate of the mixture was equivalent to a rate of thermal input (CL) of about 1 kW. The mixture was then ignited by inserting a pilot flame through the sight glass pipe. The combustion flame was stabilized in the middle portion of the porous medium A. In order to prevent porous medium B from melting, the maximum combustion temperature was limited to about 1200°C by lowering the equivalence ratio to a value $\Phi = 0.12$ which is the lowest possible value for the OWFC system to be operated without a flame extinction. After thermal equilibrium conditions of the OWFC system were reached, the OWFC system was switched to the CFRC system by operating the alternating valve rotor with half-period $t_{hp} = 20$ seconds. The equivalence ratio could be further decreased (by increasing the air flow rate) to a required value of less than 0.12, at which a good combustion stability is still maintained. Based on past experiences, a half-period of 20 seconds offers a favorable self-sustained combustion

situation, even though the experimental apparatus introduces a fresh mixture to mix with the remaining exhaust gas in the connecting pipe after a new half-period is started. The initial combustion of the mixture may, therefore, take place at Φ less than 0.12, whereas, the subsequent combustion situation will take place at $\Phi = 0.12$. These phenomena may not seriously disturb the thermal structure inside porous medium *A* provided that the connecting pipe between the combustor and the alternating valve is not too long. A steady-state condition for this experiment was reached once constant amplitude and constant average over time of the fluctuation temperatures T_1 to T_9 were obtained.

This experiment was conducted in order to further understand the combustion regime and the heat transfer characteristics of the self-sustained combustion flame of the typical gaseous mixture under reversal of the flow direction in relation to the combustor (CFRC). Comparison of thermal structure, in terms of axial temperature distribution between the CFRC system and the OWFC system, is made so as to assess the performance of the two systems. The effect of parameters controlling the performance of the CFRC system such as half-period, equivalence ratio and flow velocity is studied.

3. RESULTS AND DISCUSSION

3.1 Temperature Fluctuations

Steady-state self-sustained combustion conditions for the CFRC system were realized in the experiment. Figure 2 shows a typical fluctuation in measured temperatures for the CFRC system after switching from the OWFC system under the same experimental conditions. T_1 and T_9 are assumed to be the temperatures of the gas mixture at both ends of the combustor, even though they are 40 mm from the surface of porous medium *B*. The fluctuation in temperatures is caused by reversal of the flow direction of a cool mixture at regular time intervals. A hot exit becomes a cool inlet, and vice-versa, while the alternating valve is operating. Therefore, the amplitude of the fluctuation depends on the

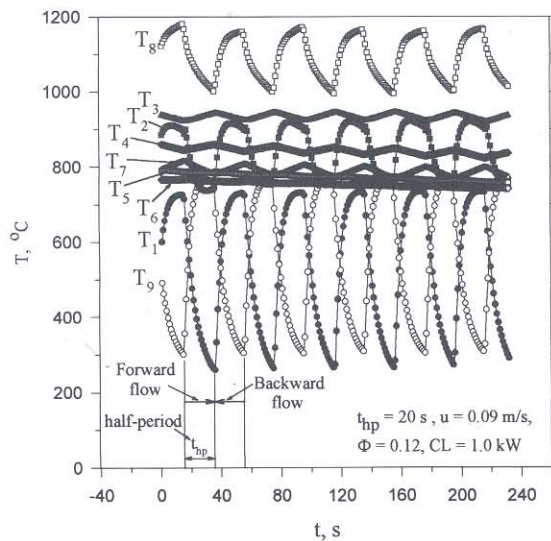

Fig. 2. Typical temperature fluctuation of the CFRC system.

location of the temperature measured. A typical large amplitude of about 200°C for T_2 occurred at the left end of the combustor, whereas at the near middle point of the combustor an amplitude of T_2 was nearly zero. Thus T_2 is nearly constant, irrespective of the reversing flow direction of the mixture. A large amplitude of T_2 and T_8 show efficient heat transfer between the solid phase and the gas phase leading to an efficient preheating of the mixture and augmentation of combustion. Although T_8 is the maximum temperature, implying that the chemical reaction zone is mainly located and stabilized there, T_3 , the second maximum temperature, could be considered as another flame location for the corresponding forward flow. The flame location should be changed with respect to the flow direction, even though an unsymmetrical change in temperature of T_3 and T_8 occurred owing to the complexity of the combustion phenomena. It is important to note that the flame was stabilized near both ends of the combustor (T_3 and T_8) medium when the experiment was switched from the OWFC system to the CFRC system for the same experimental conditions.

3.2 Comparison of Axial Temperature Distribution and Performance Between the CFRC System and the OWFC System

Comparison in performance between the two systems at relatively high and low flow velocity is very difficult due to the difference in nature of flammability limits of the two systems. In case of high flow velocity, blow-off occurred first for the OWFC system, whereas at low flow velocity, flashback occurred first for the CFRC system. Therefore, for each system, a few combustion tests have been conducted so as to obtain a common flow velocity that could yield a stable flame for both systems. Figure 3 shows a comparison of axial temperature distributions between the two systems at the same experimental condition. Temperature profiles for the two directions (backward and forward flow) of the CFRC system are the temperatures of each measured location at the end of the half-period for the

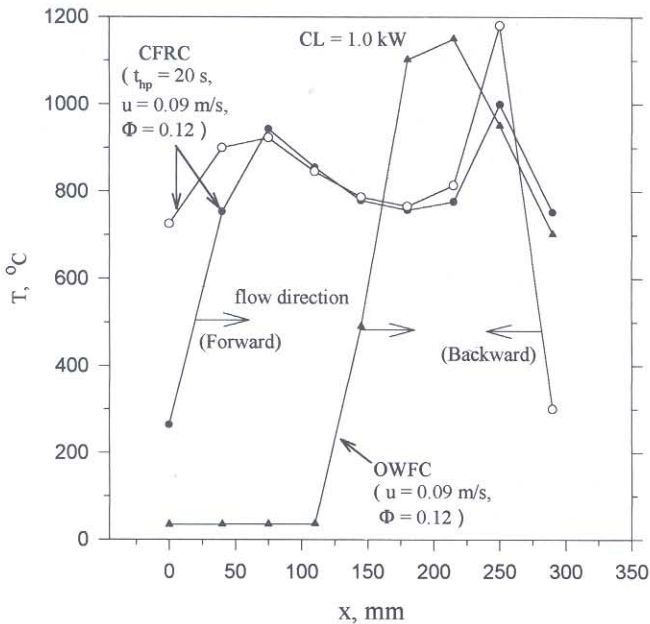

Fig. 3. Comparison of axial temperature distribution between the CFRC system and the OWFC system.

corresponding flow direction. It is clear that the temperature profiles for the CFRC have two peaks (at T_3 and T_6), even though they are less symmetrical in shape due to the complexity of the combustion regime. This implies that two reaction zones occurred in the experiment for the CFRC system. Unlike the CFRC system, the OWFC system displayed one peak temperature (at T_6), implying the reaction zone stabilized near the middle of the combustor. Performance of the CFRC in this study was verified by comparing its maximum temperature with that of the OWFC. It is important to note that both systems yield almost the same maximum flame temperature, even though the flame location of the CFRC system is closer to the combustor ends than that of the OWFC. This means that the CFRC system loses more radiative heat from flame to the environment at both ends of the combustor than that for the OWFC as indicated by a higher T_2 for the CFRC than those of the OWFC for the typical forward flow. The convective heat losses for both the CFRC and the OWFC systems are nearly identical warranted by a nearly equal exhaust temperature (T_9) at the exit for the forward flow. Therefore, based on the different flame location and the same maximum temperature and exhaust temperature, the CFRC system clearly shows a superior performance to the OWFC system. Operating the CFRC system at higher flow velocity seems to be a favorable condition. This could yield a higher flame temperature because of a decrease in radiative heat loss at both ends of the combustor resulting from the flame moving deeper into the porous medium.

3.3 Transient Change of Axial Temperature Distribution of the CFRC System

Figure 4 shows transient behavior in terms of axial temperature distributions during one half-period t_{hp} of the CFRC system with forward flow for the experimental conditions of $CL = 0.95$ kW, $\Phi = 0.067$, $t_{hp} = 30$ seconds and $u = 0.2$ m/s. At the beginning of the half-period, immediately after the change of flow direction from the backward flow to the forward flow (at $t = 0$ s), a maximum temperature could be observed at T_7 . Shortly after a change in flow direction, a maximum temperature occurs at T_4 . This maximum temperature increases during the half-period, whereas the downstream maximum (T_7) diminishes. The upstream maximum (T_4) is attributed to the heat release by chemical reaction, specifying the reaction zone. The upstream maximum (T_4) will become a new downstream maximum in the next half-period after the flow direction is changed from the forward flow to the backward flow. For short t_{hp} the downstream maximum does not vanish completely and both maxima always appear during the whole period. It is interesting to note that the cyclic reversal in flow direction at a regular time interval of the gaseous mixture drastically affect only the vicinity at both ends of the porous medium (T_1, T_2, T_8 and T_9), whereas the other part remains nearly constant except T_4 and T_7 .

3.4 Effect of Half-period on Axial Temperature Distribution of the CFRC System

Figure 5 shows the effect of half-period t_{hp} on thermal structures in terms of axial temperature profiles (end values of a half-period) for the CFRC system with forward flow for the experimental conditions of $CL = 0.95$ kW, $\Phi = 0.067$ and $u = 0.2$ m/s. When t_{hp} was varied from 2 seconds to 60 seconds, there was a moderate change in the maximum temperature (T_3). The upstream temperatures (T_1 and T_2) decreased as t_{hp} increases, whereas the downstream values (T_8 and T_9) increased. If the half-period becomes long, flame extinction may occur due to an out moving of the flame from the porous medium. Figure 6 shows the corresponding development of T_{ex} ($=T_9$ for forward flow) during a half-period. For a small half-period, the increase of T_{ex} is nearly linear and sharp before it slowly increases at the end of half-period for a long half-period. The maximum T_{ex} , which is reached at the end of the half-period, increases with the half-period. However, the time averaged exhaust temperature $T_{ex(av)}$ is only moderately effected by the half-period. The maximum temperature (T_3) as

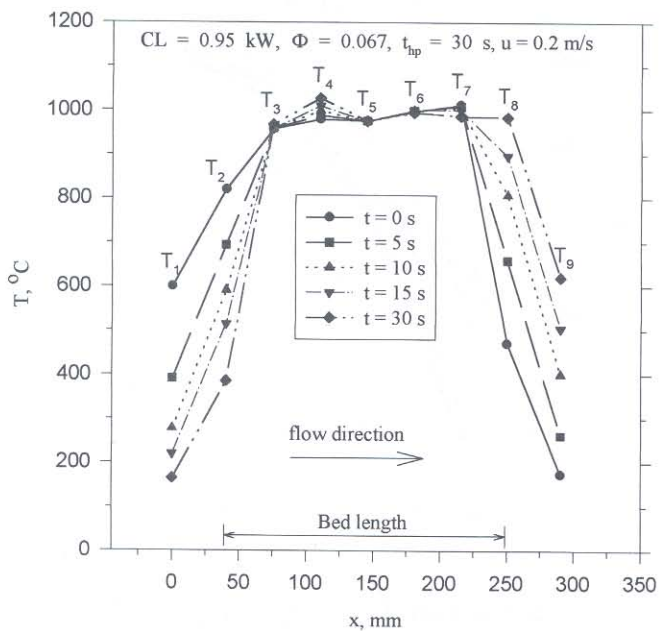

Fig. 4. Transient change of axial temperature distributions.

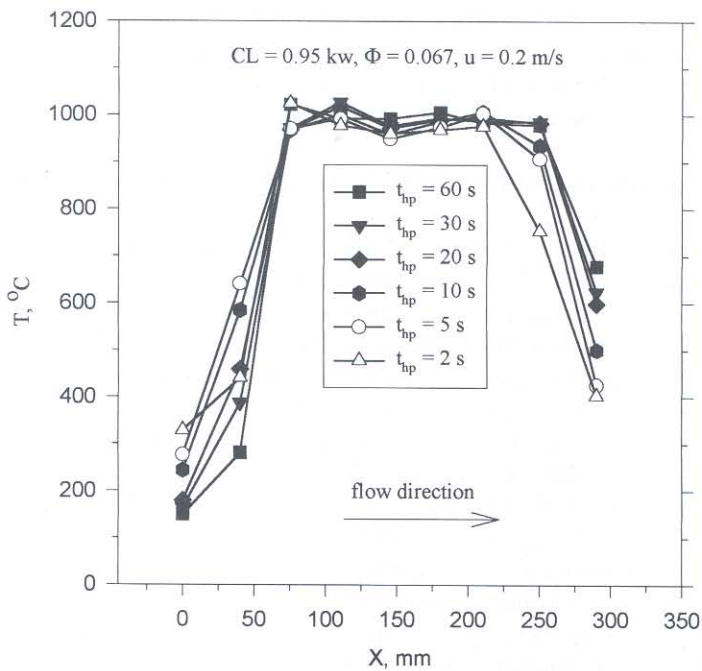

Fig. 5. Variation of axial temperature profile with half-period, t_{hp} .

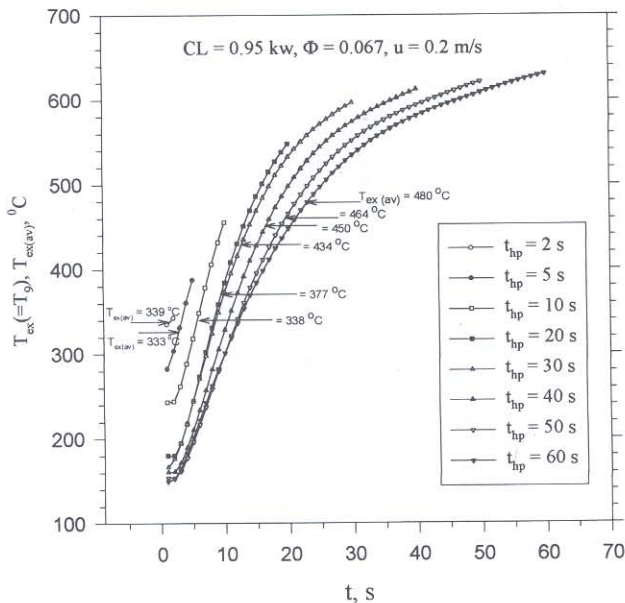

Fig. 6. Variation of $T_{ex} (= T_g)$ and $T_{ex(av)}$ with time.

shown in Fig. 5 is slightly decreased with t_{hp} . This may be attributed to the equivalence between the total released heat and the total stored heat in every considered half-period. The total released heat and the total stored heat, respectively, are defined as the heat released by the porous medium to preheat the incoming premixed gases on the inlet side of the porous medium during one half-period and the heat transferred from the exhaust gases to the porous medium when they are cooled down prior to leaving the porous medium during the same half-period [9].

3.5 Effect of Equivalence Ratio on Axial Temperature Distribution of the CFRC System

Figure 7 shows an effect of Φ on thermal structures in terms of axial temperature profiles (end values of a half-period) of the CFRC system with forward flow for the experimental conditions of $t_{hp} = 30$ s and $u = 0.2$ m/s. The equivalence ratio is expected to have a dominating effect on the thermal structure, since the thermal input is proportional to it. Within the considered range of equivalence ratio in this study, the high temperature area becomes wider as Φ increases together with an increase in the temperature gradient at both ends of the combustor. In addition to the widening of the high temperature area, a noticeable peak temperature for high Φ can be observed. The inlet temperature (T_i) and the outlet temperature (T_o) are also increased with Φ . However, the rate of increase in the exhaust temperature (T_o) is relatively high, whereas that of the inlet temperature (T_i) is negligible. The time averaged exhaust temperature $T_{ex(av)}$ increases almost linearly with Φ as shown in Fig. 8, leading to higher heat losses, which balance the increased thermal input. At a small equivalence ratio ($\Phi = 0.046$) the temperature gradients at both ends of the combustor meet almost without high temperature plateau resulting in a change of temperature profile from trapezoidal to triangular shape. If Φ is further decreased, the maximum temperature drops leading to an incomplete combustion and to an extinction of the combustion flame.

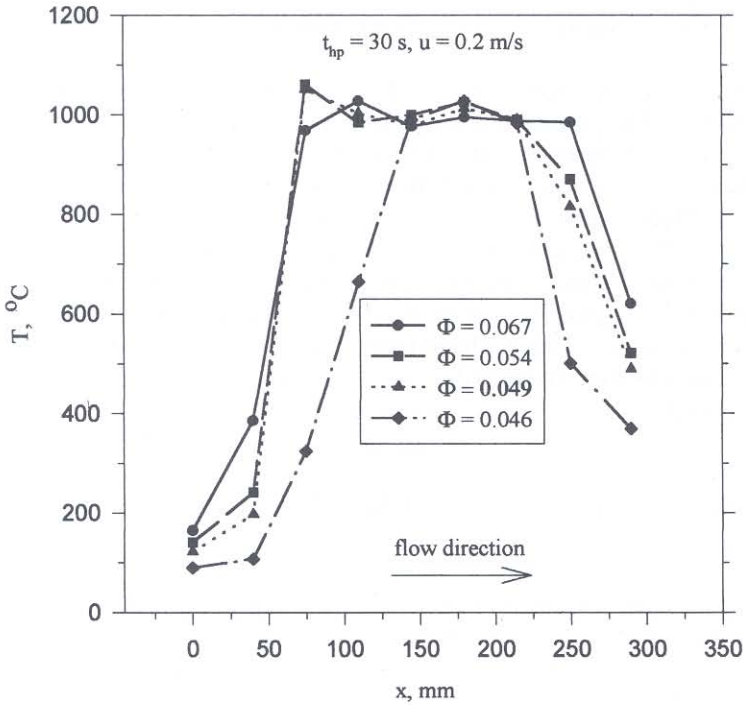

Fig. 7. Variation of axial temperature distribution at various Φ .

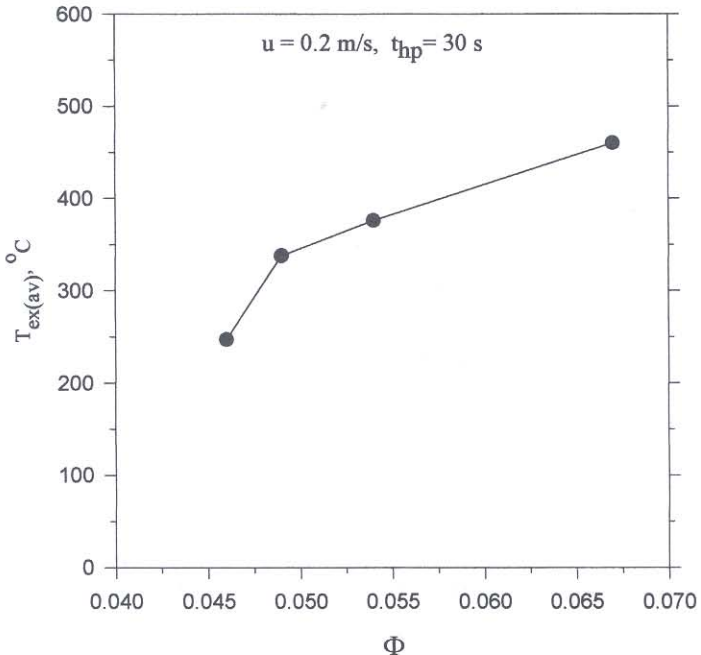

Fig. 8. Effect of Φ on $T_{ex(av)}$.

3.6 Effect of Flow Velocity u on Axial Temperature Distribution of the CFRC System

Figure 9 shows the effect of flow velocity u on axial temperature distributions (end values of a half-period) of the CFRC system with forward flow for the experimental conditions of $\Phi = 0.67$, and $(u)t_{hp} = 5.75$. The physical meaning of the product of u and t_{hp} is the displacement of the hot reaction zone during a half period once the flow direction is switched from backward flow to forward flow. If $(u)t_{hp}$ is fixed, the effect of flow velocity on the displacement is similar. Within the considered flow range, increasing the flow velocity yields a higher temperature plateau and higher exhaust temperature (T_9), which is similar to the effect on the temperature profiles with an increase in the equivalence ratio Φ , as shown in Fig. 7. Despite the proportionality of the thermal input and the gas flow velocity, Fig. 10 reveals that the time averaged exhaust temperature $T_{ex(av)}$ is not as strongly effected by changes in flow velocity as it is for the changes in the equivalence ratio as shown in Fig. 8, since the convective heat loss is also linearly varied with the gas flow velocity.

4. PRACTICAL USEFULNESS, RECOMMENDATIONS AND FUTURE RESEARCH NEEDS

This research was undertaken to explore the feasibility of combusting gaseous mixture with a cyclic flow reversal of the mixture within a porous medium. A commercial burner having high combustion temperature at relatively low equivalence ratio would have many potential applications. These may include: (i) the incineration of very lean gaseous wastes for environmental control, and (ii) state-of-the-art technology for a surface combustor-heater (SCH). This state-of-the-art technology is a combustion heat transfer device involving relatively cold heat exchange surfaces (water or gas

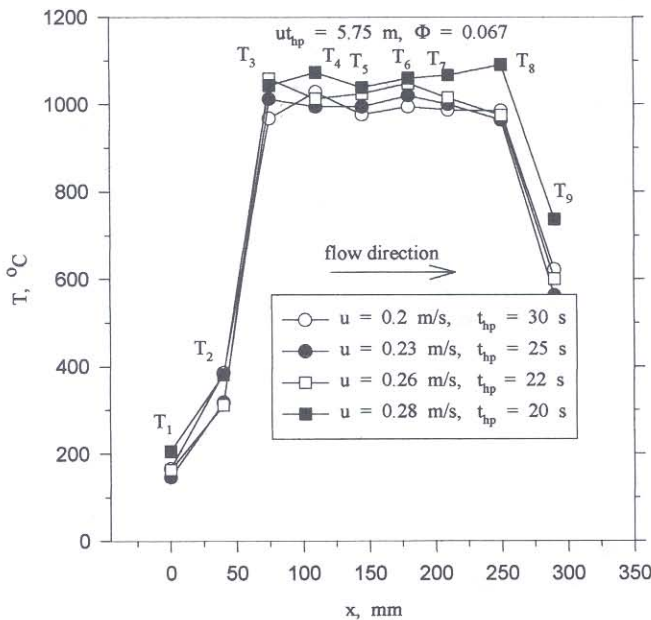

Fig. 9. Variation of axial temperature distributions at various velocity, u .

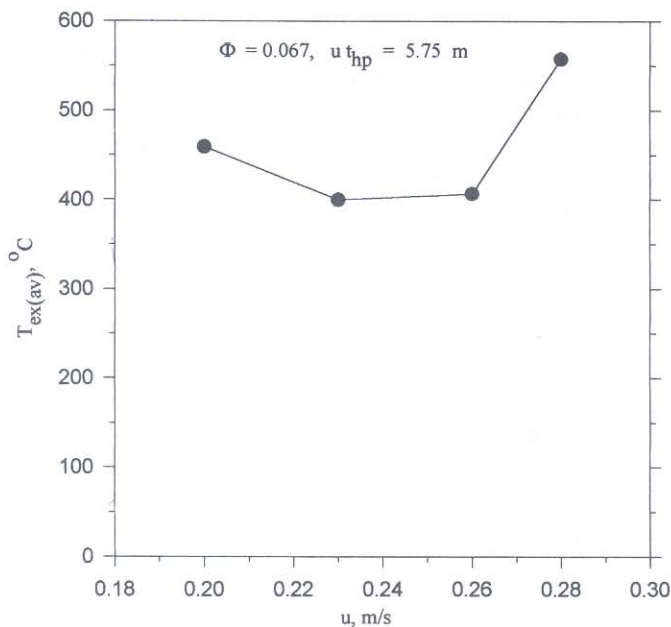

Fig. 10. Effect of velocity, u on $T_{ex(av)}$.

tube) embedded in a stationary porous medium in which gaseous fuel is burning. The concept of a cyclic flow reversal of the mixture applied to the conventional one-way flow SCH, can provide the basis for development of a more advanced, highly efficient boilers, and thermal fluid heaters for industrial applications. In the residential and commercial areas, this concept may find applications in the development of highly compact, efficient water heater and air heater.

Much work remains to be done to further investigate the combustion regime with a cyclic flow reversal of gaseous mixture in porous media. In particular, a better understanding is needed of thermal structure with regard to very high flow velocity of the mixture, whereby the reaction zone can be pushed deeper into the porous medium yielding the reduction in radiative heat losses from both ends of the porous medium. Also, effects of optical thickness and structure of the porous medium plus thermal load (water tube) on burner performance and emission characteristics must be elucidated. The ability of the burners to be scaled both up and down in capacity also needs to be examined further.

5. CONCLUSIONS

Steady-state self-sustained combustion conditions for the CFRC system were realized, even though a transient change in thermal storage of the porous medium occurred owing to a cyclic reversal in flow direction of the mixture. It was revealed that the CFRC system yields a higher quality combustion flame than without a cyclic flow reversal system (OWFC system). Under a relatively low flow velocity conditions the CFRC system is not far superior to the OWFC system in terms of the maximum gas temperature. However, in the CFRC system, the thermal storage effect induced by a cyclic reversal in flow direction of the mixture at a regular time interval plays a vital role in enhancing the internal energy recirculation, wherein the radiative heat loss from the near entrance flame to the

surroundings is compensated for by the thermal storage effect of the porous medium. Under high flow velocity, the CFRC system seems to be superior to the OWFC system in terms of flame stability limits, requiring a further study of the system in the future.

The effect of main parameters, i.e., half period, equivalence ratio and flow velocity on the thermal structure of the CFRC system were elucidated. A self-sustained combustion condition for a typical LPG fuel was observed during the experiment at the minimum equivalence ratio of $\Phi = 0.046$, of which the apparent heating value and the corresponding adiabatic flame temperature, respectively are 140 kJ/kg and 177°C,

6. NOMENCLATURE

CL	=	thermal input, kW
T	=	temperature, °C
T_{ex}	=	exhaust temperature, °C
$T_{ex(av.)}$	=	time averaged exhaust temperature, °C
t	=	time, s
t_{hp}	=	half-period, s
u	=	velocity, m/s
x	=	distance, mm
Φ	=	equivalence ratio (ratio of a theoretical air to a practical air)

7. ACKNOWLEDGEMENT

This work at the Combustion and Engine Research Laboratory (CERL), King Mongkut's University of Technology Thonburi (KMUTT) was sponsored by the National Energy Policy Office of Thailand (NEPO).

8. REFERENCES

- Weinberg, F.G. 1971. Combustion temperature: The future?. *Nature* 233: 5317.
- Hardesty, D.R., and Weinberg, F.J. 1974. Burners producing large excess enthalpies. *Combustion Science and Technology* 8: 201-214.
- Takeno, T., and Sato, K. 1979. An excess enthalpy flame theory. *Combustion Science and Technology* 20: 73-84.
- Yoshizawa, Y.; Sasaki, K.; and Echigo, R. 1988. Analytical study of the structure of radiation controlled flame. *International Journal of Heat and Mass Transfer* 31(2): 311-319.
- Sath, S.B.; Peck, R.E.; and Tong, T.W. 1990. A numerical analysis of heat transfer and combustion in porous radiant burners. *International Journal of Heat and Mass Transfer* 33 (6): 1331-1338.
- Echigo, R.; Kurusu, M.; Ichimiya, K.; and Yoshizawa, Y. 1983. Combustion augmentation of extremely low calorific gases: Application of the effective energy conversion method from gase enthalpy to thermal radiation. In *Proceedings of ASME-JSME Thermal Engineering Joint Conference*, Honolulu, 4: 99-103.
- ADTEC Co. Ltd. 1990. *A New Method of Destroying Organic Pollutants in Exhaust Air*, Commercial Report.

8. Hanamura, K.; Echigo, R.; and Zhdanok, S.A. 1993. Superadiabatic combustion in a porous medium. *International Journal of Heat and Mass Transfer* 36(13): 3201-3209.
9. Hoffmann, J.G.; Echigo, R.; Tada, S.; and Yoshida, H. 1995. Analytical study on flammable limits of reciprocating superadiabatic combustion in porous media. In *Proceedings of the 8th International Symposium on Transport Phenomena in Combustion*, San Francisco, California, 2: 1430.