



The Theoretical Framework of the Modified Organic Rankine Cycles for Improved Energy and Exergy Performances

www.ericjournal.ait.ac.th

Zubair Ali Shah^{*1}, Qun Zheng^{*}, Ghazanfar Mehdi^{*}, Naseem Ahmad^{*}, Raza Waleed⁺, Aseed Ur Rehman[#], and Asif Raza[§]

Abstract – Rapidly increasing of the energy crises, depletion of fossil fuels and its severe environmental hazards, demanded to establish the green processes. The best available solution is to convert low-grade waste heat into useful work by using the organic Rankine cycle (ORC), which reduces not only the energy shortage but also environmental problems simultaneously. This work presents the theoretical and numerical methodology using Engineering Equation Solver (EES) software to evaluate both energy and exergy analysis of the basic and three modified organic Rankine cycles. R-113 was used as a working fluid. The basic ORC system was modified by integrating internal heat exchanger, regeneration, and the combination of both. Among these four cycles, the ORC system integrating with both the internal heat exchanger and regeneration proved the best cycle, which gave the highest thermal efficiency (22.43%), exergy efficiency (33.82%), and lowest exergy destruction (44.5kW) at evaporator pressure of 2.5MPa. Furthermore, it has been concluded that the evaporator played a significant role in ORC system performance because its exergy destruction was maximum, which was enhanced by increasing its pressure.

Keywords –energy and exergy analysis, exergy destruction, internal heat exchanger, organic Rankine cycle, regeneration.

1. INTRODUCTION

Energy consumption is growing due to rapid urbanization and industrialization, which leads an increase in the use of fossil fuels. However, fossil fuels are responsible for greenhouse gas emissions, which have produced serious environmental and health problems [1]. To reduce the emissions, dependency on fossil fuels, and also meeting with the energy crisis, the improvement of energy systems is unavoidable [2]. It has been reported by the ministry of energy, the United States that from many manufacturing industries, around 60% of low and medium grade heat energy is directly exhausted to the environment [3]. Therefore, the waste heat recovery is the prominent solution to control the continuous rise in energy cost, global demand, and for the reduction of greenhouse gases as well [4]. Now a days, Organic Rankine Cycle (ORC) is the most effective and well-proven technology for low and medium temperature ranges because of its high efficiency, flexibility, simple structure, and it is also environmental friendly [5]. The main benefit of ORC is that it can be widely used in almost all fields such as solar desalination systems [6], [7], biomass combustion

[8], [9], and geothermal energy [10], [11]. Furthermore, it is more beneficial when the gas turbines have a low temperature at the exhaust [12].

Mago *et al.* [13] researched on organic Rankine cycle (ORC) by using the analysis of second-law to change waste energy into useful power from heat sources of low-grade. They selected various organic working fluids to examine the influence of different fluid's temperature at the boiling point on the ORC's performance. The investigated working fluids were R134a, R113, R245fa, R123, R245ca, propane and isobutene, and the range of boiling points were selected from -43 to 48-degree centigrade. With some conditions, the results were compared with water. The combined analysis of first and second-law was done by changing the operating parameters of the system at a different reference temperature. According to the few results reveal that ORC by using R113 unveiled maximum efficiency amongst all the organic fluids for temperatures greater than 430 K, while R245ca, R123, and R245fa showed the greatest efficiencies for temperatures range between 380K and 430 K, and for temperatures, less than 380 K, isobutene displayed the highest efficiency. They revealed that there was a strong effect of the organic-fluid boiling point on the thermal efficiency of the system.

Roy and Ashok Misra [14] presented an analysis of the regenerative organic Rankine cycle based on parametric optimization using R-134a and R-123 as working fluids during superheating at 2.5MPa under realistic conditions. A computer program had been developed to parametrically optimize and compare the system and second law efficiency, system mass flow rate, turbine work output, irreversibility rate, and irreversibility ratio with increases in turbine inlet temperature (TIT) under various heat source temperature conditions. The determined results showed that an inlet pressure of 2.70MPa gave maximum system efficiency,

* College of Power and Energy Engineering, Harbin Engineering University, Harbin, 150001, China.

+ College of Underwater Acoustic Engineering, Harbin Engineering University, Harbin, 150001, China.

Department of Mechanical Engineering, Mehran University of Engineering and Technology, Jamshoro Sindh, 76062, Pakistan.

§ College of Mechanical and Electrical Engineering, Harbin Engineering University, Harbin, 150001, China.

¹Corresponding author:
Tel: + 8613204662050.
Email: zubair_ali@hrbeu.edu.cn.

second law efficiency, and turbine work output with minimum irreversibility ratio, irreversibility rate, and system mass flow rate up to a TIT in the range of 165 - 250°C.

Xi *et al.* [15] studied the performances of three different organic Rankine cycle (ORCs) systems, containing the basic ORC (BORC) system, the single-stage regenerative ORC (SRORC) system and the double-stage regenerative ORC (DRORC) system using six different working fluids under the same waste heat conditions. The ORC systems, using each working fluid, were optimized to their optimal operating conditions, and the corresponding thermodynamic parameters under every optimal operating condition were determined. The calculated results for each working fluid, the DRORC system always provided the best thermal and exergy efficiency under optimal operating conditions, followed by the SRORC system and the BORC system had the poorest efficiency. R11 and R141b were recommended as appropriate working fluids for ORC systems, due to their better thermodynamic performances.

Hung [16] worked on dry fluids as a working fluid, and he used Benzene (C₆H₆), R123, p-Xylene (C₈H₁₀), and Toluene (C₇H₈) for investigation. According to his investigated working fluids, the highest efficiency was achieved by, while the lowest efficiency is achieved by Benzene. His research work also exposed that irreversibility was contiguous to the heat source type. In general, to recover waste heat with high temperature, the lowest irreversibility fluid was p-Xylene, while R123 and R113 had good performance to recover waste heat of low temperature.

The three regenerative dual-loop organic (ORC) systems were proposed by Shu G., *et al.* [17] to equate with the normal DORC system. The waste heat of the engine, coolant, residual heat and exhaust of the HT loop was recuperating in the mentioned four systems. Siloxane and water were selected as working fluid in the HT loop, and subcritical and transcritical cycles were compared. R143a was used as a working fluid in LT loop and adopted transcritical cycle. The exergy efficiency and net power output are selected objective functions. According to the mathematical model and engine data, optimization was carried out of the operational parameters, and component irreversibility analysis had been done. The results demonstrated that the low condensation temperature of HT loop was useful for performance optimization. The turbine inlet temperature for wet fluids of THT was high in the subcritical cycle and for dry fluids, it was low in transcritical and subcritical cycles. Maximum exergy efficiency and net output power were gained when water was selected as working fluid in the HT loops and in the system no regenerator was used. 39.67 kW and 42.98% were corresponding values when working fluid of siloxane was used in HT loop, DORC with dual regenerators, performed well. For evaluated all systems, turbine TLT, and the condenser CLT irreversibilities are huge.

Long *et al.* [18] took the external exergy and internal efficiencies to examine the influence of ORC performance with different working fluids, and a

simplified internal exergy efficiency model was suggested to show that effect. The calculation consequences exhibited the working fluid thermo-physical properties and a small influence on the efficiency, internal exergy, but their role was not important in defining the efficiency of external exergy.

Quoilin [19] investigated the performance optimization of waste heat recovery by using a small scale basic ORC system. Wei [20] focused on the thermodynamic optimization and the performance analysis of basic ORC system by using different working fluids. It was observed that by using the maximum exhaust heat, net power output was improved significantly. Liu [21] studied and analyzed the impacts of various working fluids on the performance parameters such as total heat recovery and thermal efficiency of the ORC system. Wang [22] discussed the low-temperature geothermal ORC system, and it was proven from the results that performance efficiency was significantly impacted by the evaporation temperature and physical properties of the working fluid. Sun [23] investigated the two important parameters for the working performance of ORC. It was observed that the net power generation could be investigated by using controlled and uncontrolled variables of the linear functions and thermal efficiency was studied by using a quadratic function.

Furthermore, there are few methods that can enhance the performance of ORC, such as system operating optimization, reduction of ORC condensing temperature, EORC (incorporating vapor-liquid ejector), RORC (reheat organic Rankine cycle), DLORC (dual loop ORC), combining feed water heating, incorporating internal heat exchanger, regeneration and integrating with other the system techniques. Xi [24], Imran [25], and Mago [26] investigated the performance of ORC by using regeneration, and an improvement in cycle efficiency was observed. Li [27], Saleh [28], and Uusitalo [29] studied and proved that the efficiency of ORC, by incorporating internal heat exchanger, was also increased. In this study, firstly we used the internal heat exchanger and regeneration separately and secondly in combination. It was observed that the performance of ORC was significantly improved when the internal heat exchanger and regeneration incorporated together.

Furthermore, numerous studies have been performed on the ORC, such as performance analysis and modeling, proper selection of working fluid, system optimization, *etc.* But the comprehensive energy and exergy analysis of basic and three modified ORC systems for the thermodynamic performances were hard to find. The energy conversion process can be evaluated by using the energy analysis method. But it has certain limitations and not describing the irreversibility of processes and energy quality in the system. However, the working potential of system can be characterized by exergy analysis such as evaluation of exergy losses and its location. This also gave a realistic view of thermodynamics inefficiencies in the system which is very helpful for further improvements [30]-[33].

The main theme of this theoretical and numerical work is to establish a structure for the energy and exergy

performance analysis of basic and three modified ORCs incorporating internal heat exchanger, regeneration and both internal heat exchanger and regeneration, which was used to calculate the destruction rate of exergy in each component, energy and exergy efficiencies in all over system. This study found the important sources of exergy destruction and other losses in the system. Furthermore, the behavior of the system performance has been observed with varying operating conditions, and also it provides a reference for future studies.

2. MATERIALS AND METHODOLOGY

2.1 Systems Description

The basic and three modified ORC systems are represented in Figure 1. Four thermodynamic processes in the basic ORC system, as shown in Figure 1(a): Isentropic compression 1-2 (pump), heat addition at constant pressure 2-3 (evaporator), isentropic expansion 3-4 (turbine), heat rejection at constant pressure 4-1

(condenser). Modified ORC integrating the internal heat exchanger (IHX) system is presented in Figure 1(b). Because the outlet temperature of the turbine is significantly greater than the outlet temperature of the condenser; the obtained high-temperature stream can be used to preheat the liquid before it moves to the evaporator. Thus, IHX has been placed in between the turbine outlet and condenser inlet. Heat source reduced the required power; therefore, the efficiency of the system was improved. Modified ORC system with regeneration is illustrated in Figure 1(c). FWH is integrated into the basic ORC system. A part of vapors was extracted from the turbine at intermediate pressure and was directly sent to the feedwater heater for regeneration. However, the remaining vapors expand to produce work until the pressure drops to the condensing pressure. After that, low temperature and pressure vapors enter into the condenser, where the saturated liquid state was achieved by the cooling process.

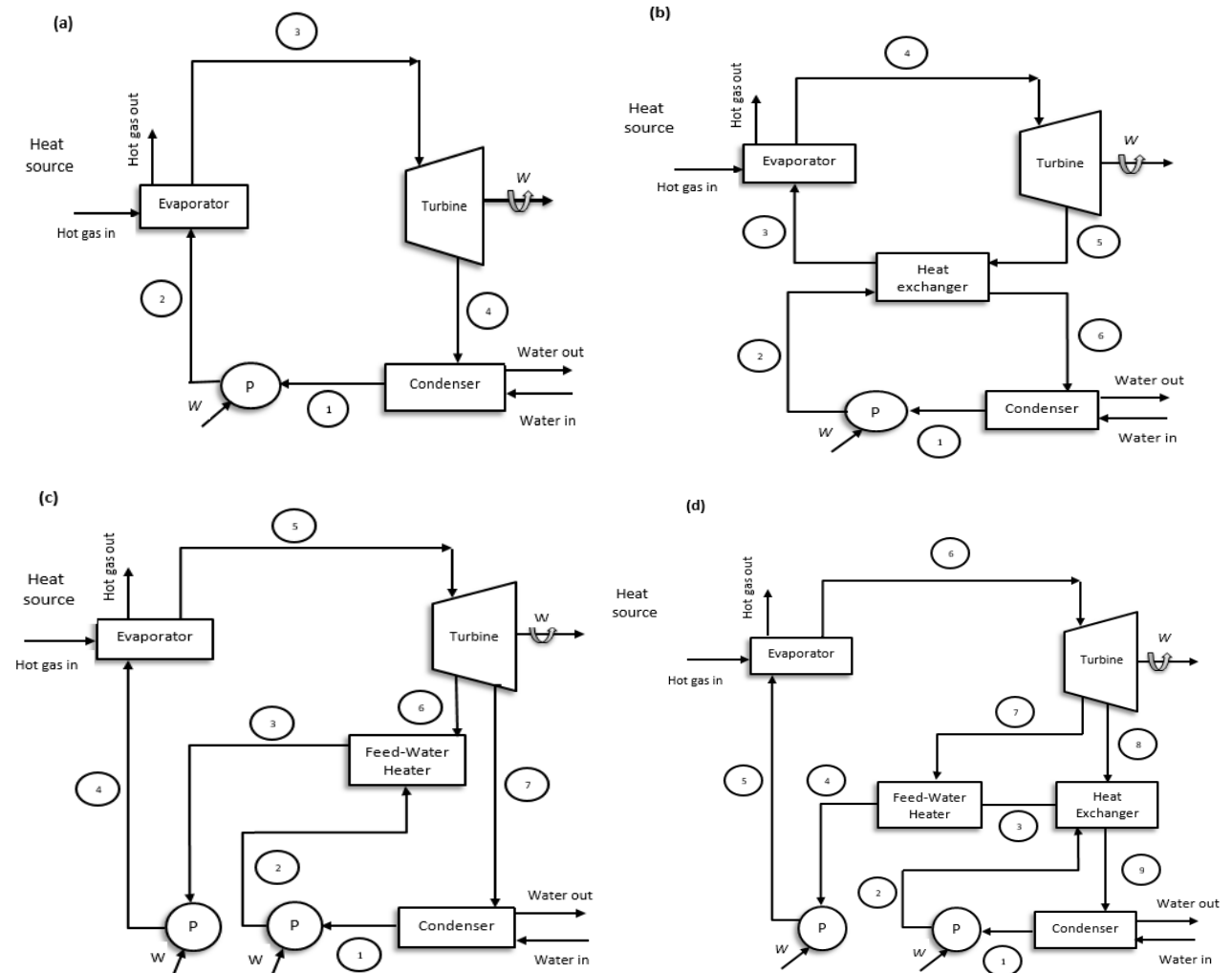

Fig. 1. Basic and three modified ORC systems (a) basic ORC (b) ORC integrated with internal heat exchanger (c) ORC integrated with regeneration (d) ORC integrated with both the internal heat exchanger and regeneration.

Modified ORC integrated with both internal heat exchanger regeneration is represented in Figure 1(d). The computational equations for the basic and three modified ORC systems are represented in Table 1. The

topological procedure was used to analyze the energy and exergy performance of ORC systems [30], [35], [36].

2.2 Thermodynamic Assumptions

R-113 is taken as the working fluid, which is the most suitable for ORC; it already has been demonstrated already [26], [37], [38]. For the pump and turbine, the isentropic efficiencies are 85% and 80%, respectively. The evaporator pressure and condenser temperature are fixed at 2500kPa and 298k, respectively. Heat is gained by ORC system at the frequency of 252 KW from a heat source. For the reference state, the determined pressure and temperature are 100kPa and 298 K, respectively. The steady stream of nitrogen is considered as hot inlet gas at the pressure of 100kPa and a temperature of 573 K for the evaporator. The assumed intermediate pressure with regeneration for the modified ORC is 1000kPa. Moreover, both pumps will keep performing at the same efficiency, and they will not be influenced by different flow conditions. Besides that, for ORCs thermodynamic analysis, steady-state condition, it is assumed that are no heat and pressure losses in all equipment.

3. EXERGY ANALYSIS

The maximum work capacity of the system is measured by exergy analysis in order to bring the system in an equilibrium state with its surroundings [39], [40]. Energy analysis only provides information about the energy conversion efficiency. However, exergy analysis measures the energy quality [41]. The irreversibility of the system is measured by the exergy destruction, which is the major source of the performance losses. Thus, the exergy destruction magnitude, its location, and thermodynamic efficiencies of the system can be evaluated by exergy analysis [32]. The exergy flow rate is composed of chemical, physical, kinetic, and potential exergies in Equation 1 [32], [33], [39].

$$E = \dot{E}_{ch} + \dot{E}_{ph} + \dot{E}_k + \dot{E}_p \quad (1)$$

Specific exergy rate is:

$$e = e_k + e_p + e_{ch} + e_{ph} \quad (2)$$

$$e = \frac{\dot{E}}{\dot{m}} \quad (3)$$

In this study, we have assumed that the kinetic (e_k) and potential (e_p) and (e_{ch}) exergies are negligible. The Equation 4 is used to evaluate the physical exergy for water and steam.

$$e_{ph} = h - h_o - T_o (s - s_o) \quad (4)$$

For an ideal gas,

$$e_{ph} = h - h_o - T_o \left[s - s_o - R \ln \left(\frac{P}{P_o} \right) \right] \quad (5)$$

S and h are the entropy and specific enthalpy of the substance, respectively. Whereas s_o and h_o are entropy and enthalpy at the state determined pressure and temperature (P_o and T_o).

3.1 Influence Coefficient

It is the ratio of available exergy (E_i^a) of an element to the total available exergy (E_{total}^a) of the system.

$$\beta_i = \frac{E_i^a}{E_{total}^a} \quad (6)$$

β represents the impact of each component in the total system. Through this method, an important component can be identified, which has more impact on the efficiencies of the system.

3.2 Exergy Efficiency

The ratio of consumed exergy of an element to the available exergy of that element is said to be exergy efficiency, and it can be calculated from:

$$\eta_{exergy}^i = \frac{E_i^u}{E_i^a} \quad (7)$$

Where E_i^u and E_i^a are the consumed exergy and available exergy of the element.

However, the ratio of total consumed exergy to total available exergy is said to be total exergy efficiency and it can be calculated from:

$$\eta_{exergy, total} = \frac{E_{total}^u}{E_{total}^a} \quad (8)$$

3.3 Degree of Thermodynamic Perfection (DTP α)

It is the ratio of exit exergy of the element i to the exergy flow of the same element is said to be DTP. It can be determined from:

$$\alpha_i = \frac{E_i^{out}}{E_i^{in}} = 1 - \frac{\phi_i}{E_i^{in}} \quad (9)$$

In the above Equation 9, exergy loss ϕ_i can be calculated from Equation 10.

$$\phi_i = E_i^{in} - E_i^{out} \quad (10)$$

Where E_i^{out} and E_i^{in} are the exergy outlet from the element i and the exergy flow rate, respectively.

The ideal value of α is 1 for each element, but it happens whenever the exergy losses of the elements are zero. If the value of DTP (α) is high, it shows that the thermodynamic performance of the element is better.

Equations 11 and 12 are used to evaluate the total loss of exergy and thermodynamic degree (DTP) of the system, respectively.

$$\phi_{total} = \sum_{i=1}^n \phi_i \quad (11)$$

$$\alpha_{total} = \frac{E_{total}^{out}}{E_{total}^{in}} \quad (12)$$

Table 1. Thermodynamics equations to calculate ORC systems.

Components	Equation
Basic ORC pump (1-2)	$\dot{W}_p = \frac{\dot{W}_{p,ideal}}{\eta_p} = \frac{\dot{m}(h_1 - h_{2s})}{\eta_p}$
Evaporator (2-3)	$\dot{Q}_e = \dot{m}(h_3 - h_2)$
Turbine (3-4)	$\dot{W}_t = \dot{W}_{t,ideal} \eta_t = \dot{m}(h_3 - h_{4s}) \eta_t$
Condenser (4-1)	$\dot{Q}_c = \dot{m}(h_1 - h_4)$
Cycle efficiency	$\eta_{cycle} = \frac{\dot{W}_p + \dot{W}_t}{\dot{Q}_e}$
Modified ORC integrated with internal heat exchanger	
Pump (1–2)	$\dot{W}_p = \frac{\dot{W}_{p,ideal}}{\eta_p} = \frac{\dot{m}(h_1 - h_{2s})}{\eta_p}$
An internal heat exchanger (2–3 & 5–6)	$\dot{Q}_h = \dot{m}(h_5 - h_6)$
Evaporator (3–4)	$\dot{Q}_e = \dot{m}(h_4 - h_3)$
Turbine (4–5)	$\dot{W}_t = \dot{W}_{t,ideal} \eta_t = \dot{m}(h_4 - h_{5s}) \eta_t$
Condenser (6–1)	$\dot{Q}_c = \dot{m}(h_1 - h_6)$
Cycle efficiency	$\eta_{cycle} = \frac{\dot{W}_p + \dot{W}_t}{\dot{Q}_e}$
Modified ORC integrated with regenerative	
Pump (1–2 & 3–4)	$\dot{W}_p = \dot{m} \left[\frac{(1 - X)(h_1 - h_{2s}) + (h_3 - h_{4s})}{\eta_p} \right]$
Feed-water heater (6–3–2)	$X = \frac{h_3 - h_2}{h_6 - h_4}$
Turbine (5–6 & 5–7)	$\dot{W}_t = \dot{W}_{t,ideal} \eta_t = \dot{m} \eta_t [(h_5 - h_{7s}) + X(h_{7s} - h_{6s})]$
Condenser (7–1)	$\dot{Q}_c = \dot{m}(1 - X)(h_1 - h_7)$
Cycle efficiency	$\eta_{cycle} = \frac{\dot{W}_p + \dot{W}_t}{\dot{Q}_e}$
Modified ORC integrated with both the internal heat exchanger and regeneration	
Pump (1–2 & 4–5)	$\dot{W}_p = \dot{m} \left[\frac{(1 - X)(h_1 - h_{2s}) + (h_4 - h_{5s})}{\eta_p} \right]$
An internal heat exchanger (2–3 & 8–9)	$\dot{Q}_h = \dot{m}(1 - X)(h_8 - h_9)$
Feed-water heater (7–4–3)	$X = \frac{h_4 - h_3}{h_7 - h_3}$
Evaporator (5–6)	$\dot{Q}_e = \dot{m}(h_6 - h_5)$
Turbine (6–7 & 6–8)	$\dot{W}_t = \dot{W}_{t,ideal} \eta_t$ $= \dot{m} \eta_t [(h_6 - h_{8s}) + X(h_{8s} - h_{7s})]$
Condenser (9–1)	$\dot{Q}_c = \dot{m}(1 - X)(h_1 - h_9)$
Cycle efficiency	$\eta_{cycle} = \frac{\dot{W}_p + \dot{W}_t}{\dot{Q}_e}$

3.4 Flow Conditions

Using the following pressure and temperature conditions, the flow exergy (E) and specific exergy (Ψ)

are determined for each cycle by using equations as written in Table 1. The obtained results from the equations are arranged in Table 2 and Table 3.

Table 2. Flow conditions for basic and modified ORC integrated with internal heat exchanger.

Basic ORC					ORC integrating internal heat exchanger			
Points	P (kPa)	T (°C)	E (kW)	Ψ (kJ/kg)	P (kPa)	T (°C)	E (kW)	Ψ (kJ/kg)
1	46	25	0	0	48	25	0	0
2	2500	26.1	1.525	1.403	2500	26.1	1.605	1.403
3	2500	195	69.34	63.8	2500	55	3.114	2.723
4	46	87	4.655	4.283	2500	195	72.97	63.8
5	100	300	176.3	88.13	48	92	5.637	4.928
6	100	183	65.31	32.65	48	56	3.655	3.105
7	100	25	0	0	100	300	169	84.51
8	100	35	3.467	0.6865	100	184	66.03	33.02
9					100	25	0	0
10					100	35	3.452	0.6865

Table 3. Flow conditions for modified ORC integrated with regeneration, and modified ORC integrated with both the internal heat exchanger and regeneration.

Modified ORC integrating with regeneration					Modified ORC integrating with both the IHX and regeneration			
Points	P (kPa)	T (°C)	E (kW)	Ψ (kJ/kg)	P (kPa)	T (°C)	E (kW)	Ψ (kJ/kg)
1	48	25	0	0	48	25	0	0
2	1000	25.4	0.4445	0.4453	1000	25.4	0.4678	0.4453
3	1000	138.3	34.07	17.83	1000	40	0.823	0.7834
4	2500	141.2	36.47	19.09	1000	138.3	33.77	17.83
5	2500	195	121.9	63.8	2500	140.2	36.15	19.09
6	1000	154.6	47.21	51.73	2500	195	120.8	63.8
7	48	90	4.919	4.928	1000	157.3	43.63	51.73
8	100	300	177.5	84.51	48	92	5.177	4.928
9	100	188	72.43	34.49	48	74	3.46	3.294
10	100	25	0	0	100	300	177.5	84.51
11	100	35	3.192	0.686	100	189	73.21	34.86
12					100	25	0	0
13					100	35	3.183	0.6865

Table 4. Results for basic and three modified ORC systems (a) Basic ORC (b) ORC integrating with Internal Heat Exchanger (c) ORC integrating with regeneration (d) ORC integrating with the IHX and regeneration

Parameters	Units	ORC(a)	ORC(b)	ORC(c)	ORC(d)
Pump power	kW	1.96	1.887	3.213	3.217
Evaporator duty	kW	252	252	252	252
Turbine power	kW	51	55.6	57.9	59.74
Condenser duty	kW	202	209.5	194.5	193.9
Heat exchanger duty	kW	-	13.38	-	10.82
Heat exchanger duty	kW	-	13.38	-	10.82
Mass flow (nitrogen gas)	kg/s	2	2	2.1	2.1
Mass flow (water)	kg/s	4.762	5	4.65	4.636
Mass flow (organic fluid)	kg/s	1.025	1.144	1.911	1.894
Net power	kW	52.03	57.48	61.11	62.95
Thermal efficiency	%	19.31	21.31	21.7	22.43

4. RESULTS AND DISCUSSIONS

4.1 Exergy Evolution

The functioning conditions of flow rates are required for computation of the exergy flow rates. Parametric data of

the flow is illustrated in Tables 1 to 3 for basic and three modified ORC systems. Tables contain the values of pressure, temperature, the flow rate of exergy, and specific exergy (Ψ) for each component. By using the data from Tables 1 to 3, for the basic and three modified

ORC systems, the evaporator duty, pump power, turbine power, condenser duty, heat exchanger duty, the mass flow rate of water, nitrogen gas and organic fluid, net power, and thermal efficiency are calculated and presented in Table 4.

Tables 5 to 8 present the thermodynamic performances of the basic and three modified ORC

systems, respectively. The tables contain the values of exergy loss (ϕ), inlet and outlet exergy, DTP (α), exergy efficiency, consumed and available exergy, and coefficient of influence (β) for each component. Furthermore, the DTP (α), exergy efficiency, and exergy loss of the total system were calculated.

Table 5. Evaluation of exergy for basic ORC.

Elements	ϕ_i (kW)	α_i (%)	E_i^{in} (kW)	E_i^{out} (kW)	η_{energy}^i (%)	E_a^i (kW)	E_u^i (kW)	β_i (%)
Pump	0.2529	85.04	1.691	1.438	85.04	1.691	1.438	1.002
Evaporator	39.77	76.67	170.5	130.7	85.04	103.7	63.94	61.4
Turbine	10.65	83.71	65.38	54.73	61.65	60.99	50.34	36.14
Condenser	1.21	74.48	4.293	3.261	82.53	4.389	3.269	2.601
Total system	51.88	69.7	170.7	119	29.83	168.8	50.34	-

Table 6. Evaluation of exergy for modified ORC integrating with internal heat exchanger.

Elements	ϕ_i (kW)	α_i (%)	E_i^{in} (kW)	E_i^{out} (kW)	η_{energy}^i (%)	E_a^i (kW)	E_u^i (kW)	β_i (%)
Pump	0.2823	85.04	1.887	1.605	85.04	1.887	1.605	1.108
Evaporator	33.13	80.75	172.1	139	67.83	103	69.86	60.49
Turbine	11.74	83.92	72.97	61.23	82.57	67.33	55.6	39.55
Condenser	0.2029	94.45	3.767	3.465	94.16	3.767	3.465	2.147
Heat exchanger	0.4725	93.47	7.241	6.881	76.16	1.87	1.51	1.164
Total system	45.83	73.19	170.9	125.1	32.66	170.2	55.6	-

Table 7. Evaluation of exergy for modified ORC integrating with regeneration.

Elements	ϕ_i (kW)	α_i (%)	E_i^{in} (kW)	E_i^{out} (kW)	η_{energy}^i (%)	E_a^i (kW)	E_u^i (kW)	β_i (%)
Pump 1	0.2914	99.21	36.76	36.47	89.17	2.691	2.399	1.523
Evaporator	19.6	90.21	213.19	194.3	81.34	105	85.44	59.64
Turbine	11.88	90.25	121.9	110	82.97	69.78	57.9	39.55
Condenser	1.727	64.9	4.919	3.192	64.9	4.919	3.192	2.784
Pump 2	0.0783	85.01	0.5228	0.445	85.01	0.5228	0.445	0.295
Feed water heater	13.59	71.49	47.66	34.07	71.49	47.66	34.07	26.98
Total system	47.16	73.9	180.7	133.5	32.78	176.7	57.9	=

Table 8. Evaluation of exergy for modified ORC integrating with the IHX and regeneration.

Elements	ϕ_i (kW)	α_i (%)	E_i^{in} (kW)	E_i^{out} (kW)	η_{energy}^i (%)	E_a^i (kW)	E_u^i (kW)	β_i (%)
Pump 1	0.288	99.2	36.44	36.15	89.17	2.667	2.378	1.51
Evaporator	19.6	90.84	213.6	194	81.23	104.3	84.69	59.03
Turbine	12.29	89.83	120.8	108.5	82.93	72.03	59.74	40.78
Condenser	0.277	91.98	3.46	3.186	91.97	3.46	3.186	1.97
Pump 2	0.082	85	0.551	0.4678	85	0.551	0.4678	0.31
IHX	1.362	75.87	5.645	4.283	20.68	1.717	0.3552	0.97
Feed water heater	10.68	75.97	44.45	33.77	75.79	44.45	33.77	25.16
Total system	44.56	75.34	180.7	136.1	33.82	176.6	59.74	-

It has been concluded from the Tables 5 to 8 that basic ORC has the maximum total exergy loss (51.8kW) and minimum exergy efficiency (29.83%) and it was

also observed that the evaporator has a major contribution to ORC system performance as compared to other working components. In the evaporator, the

maximum exergy loss occurs because of the irreversibility due to heat transfer over a determinate temperature difference. In basic ORC, exergy loss in the evaporator is 39.77 kW, which was reduced to 33.13kW, 19.6kW and 19.5kW by using three modified ORC systems ORC (b) integrating with internal heat exchanger, ORC (c) integrating with regeneration and ORC (d) integrating with both the internal heat exchanger and regeneration, respectively. Because of the exergy loss, the overall exergy efficiency of Basic ORC from 29.83% to 32.6%, 32.78%, and 33.82% has been improved for modified three ORC systems (b), (c) and (d), separately.

Furthermore, with the decrease in exergy loss, the DTP (α) was increased from 69.7%, 73.1%, 73.9% and 75.34% for basic ORC (a), and three modified ORC systems (b) internal heat exchanger (c) regeneration (d) combination of both (b) and (c), respectively.

Important results has been obtained from energy and exergy analysis of ORC system integrated with

regeneration (c) and with both the internal heat exchanger and regeneration (d) gave the higher energy and exergy efficiencies of the system *i.e.* 21.7% and 32.78% for ORC (c) and 22.43% and 33.82% for ORC (d). This is because the temperature at the inlet of the evaporator is increased but from the hot stream of nitrogen gas (252 kW), the available heat for the evaporator was the same.

ORC by means of an internal heat exchanger and regeneration put more benefits forward because of integration such as high-power generation and reduction in cold utility requirements. However, it is worth noting that because of Integration, the complexity of the flow scheme and the capital expenditure of the total system is also enlarged. In such a way, the total exergy loss in the system is decreased (44.56kW) due to this the thermodynamic efficiency of ORC (d) is increased, and also enhancement on the DTP (α) was 75.34%.

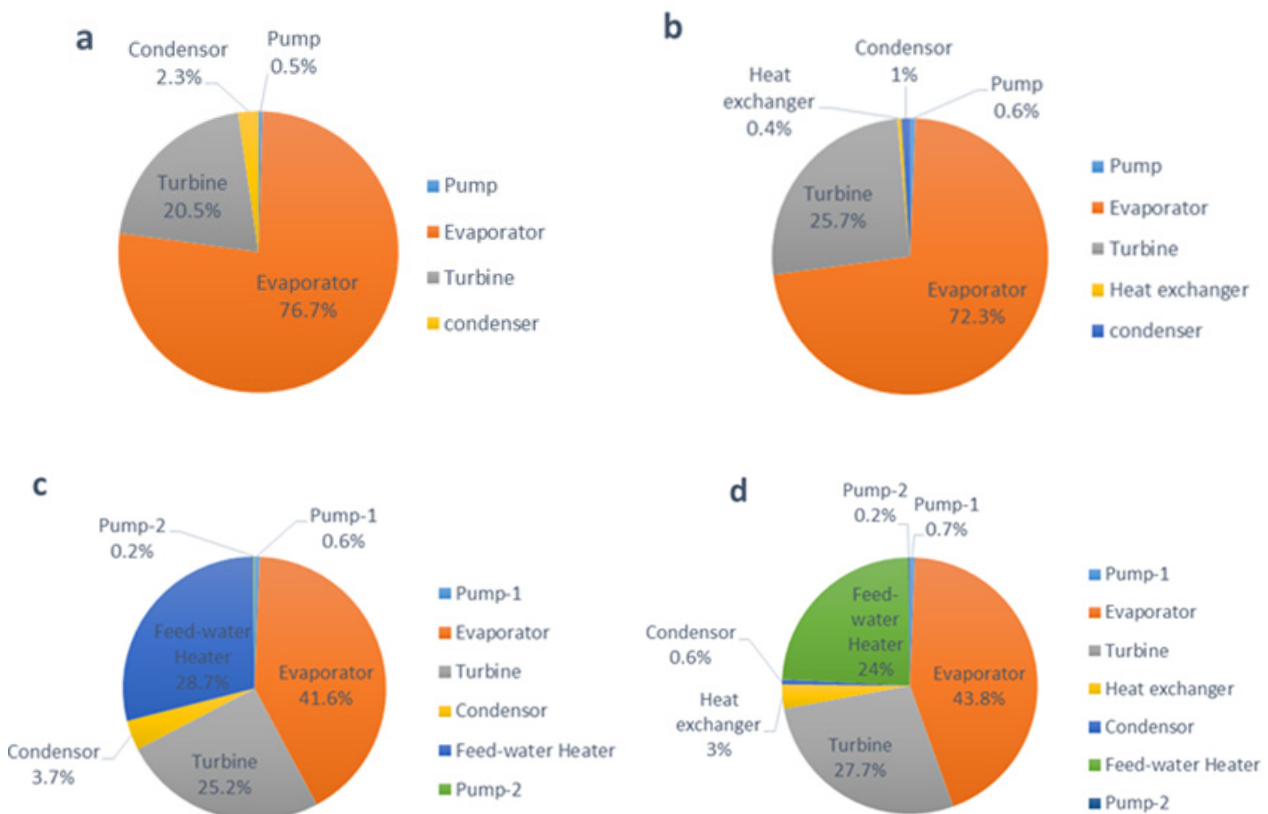

Fig. 2. Exergy destruction in each component of (a) basic ORC (b) ORC integrated with internal heat exchanger (c) ORC integrated with regeneration (d) ORC integrated with both the internal heat exchanger and regeneration.

A comprehensive study about the percentage of exergy destruction in all components as compared with the total losses of a system for the basic and three modified ORC systems is shown in Figure 2. It can be observed from Figure 2 that the turbine and evaporator are the important sources for the maximum exergy losses in the system. As compared with ORC (a) and (b), ORC (c) and (d), have lower exergy destruction in the evaporator. The feedwater heater is the major source of

exergy reduction for the ORC (c) and (d), which is 28.8% and 24%, respectively.

4.2 Impact of evaporator pressure on ORC system performance

The relation between evaporator cycle energy and exergy efficiencies for all ORC cases is shown in Figure 3 (a) and (b), respectively. It is proved that in all the instances of ORC systems, with the increase of evaporator pressure ranges from 1600kPa to 2500kPa,

the energy and exergy efficiencies are improved. However, the ORC system integrating both regeneration and internal heat exchanger (d) show the maximum

thermal and exergy efficiencies as compared to other cycles.

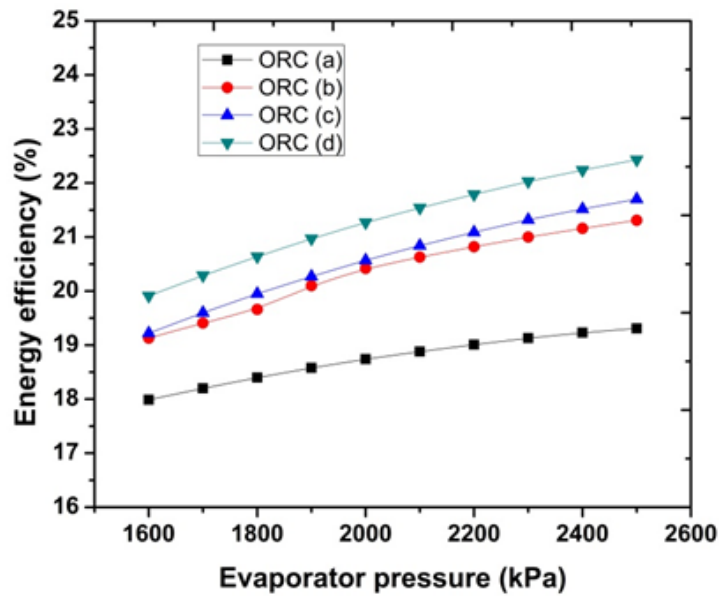

Fig. 3. (a) Behaviour of energy efficiency with evaporator pressure.

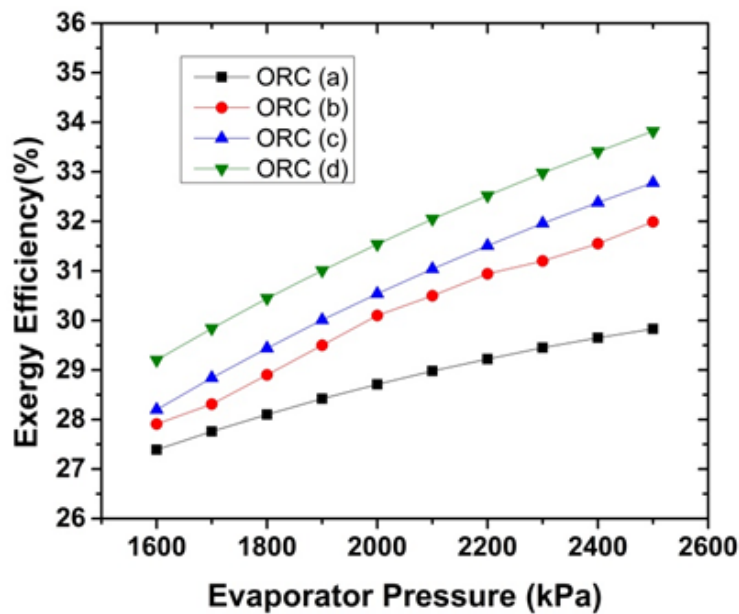

Fig. 3. (b) Behaviour of exergy efficiency with evaporator pressure.

Figure 4 represents the relation between evaporator pressure and overall exergy loss. It is observed from the figure that, by increasing the pressure of the evaporator, the overall exergy loss of the cycle is decreased. Because, with the increase in the evaporator pressure,

leads to reduce the temperature difference between evaporator temperature and hot gas nitrogen stream. This reduction in temperature difference is responsible for the increase in the consumed exergy, which decreases the system's exergy losses

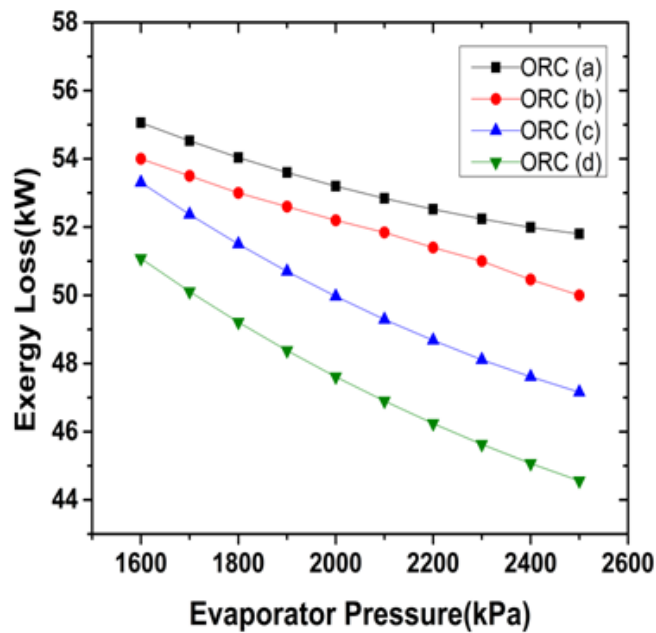

Fig. 4. The behavior of exergy loss with evaporator pressure.

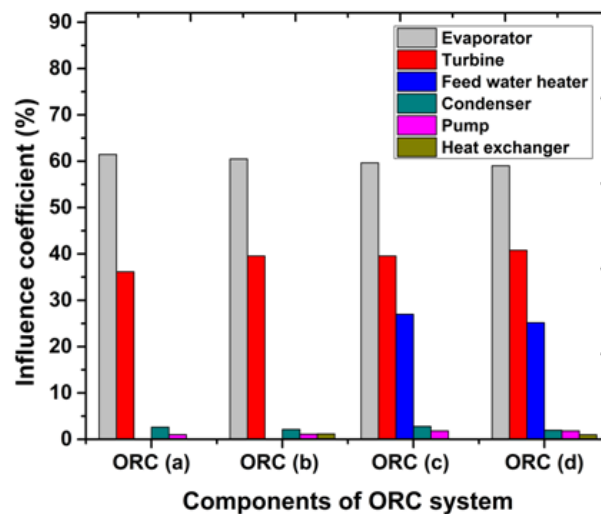

Fig. 5. Influence coefficient of components basic ORC (a), modified ORC integrated with IHX (b), modified ORC integrated with regeneration(c) and modified ORC with both the internal heat exchanger and regeneration (d).

Figure 5 shows the influence coefficient of each component of basic as well modified ORCs. It can be seen that the evaporator has the maximum value of influence coefficient in each cycle, which means that it has more impact on ORCs performance as compare to other components.

5. CONCLUSION

Incorporating R-113 as working fluid, a comprehensive energy and exergy analysis for ORCs is shown in this paper. It is inferred from the above discussion that the basic ORC system (a) performance can be enhanced by integrating the internal heat exchanger in ORC system

(b), integrating with regeneration in ORC system (c) and finally integrating with both the internal heat exchanger and regeneration ORC (d). To analyze the detailed thermodynamic parameters such as exergy efficiency, influence coefficient (β), and thermodynamic perfection (α) are also determined. It was proved that the basic ORC possesses the least thermal efficiency (19.31%), least exergy efficiency (29.83%), and the greatest total exergy loss (51.8kW). Moreover, the highest part of exergy loss from the system is by the evaporator (39.77kW). There is a reduction in exergy loss by the improved ORC (b) incorporating internal heat exchanger, ORC (c) regeneration, and ORC (d)

incorporating both internal heat exchanger as well as regeneration, 33.13kW, 19.6kW and 19.5kW respectively. The analysis shows that the major part is played by the evaporator in the ORCs performance, and the highest contribution of exergy destruction has a relationship with it. The modification improves the exergy destruction because of the rise in the feed temperature of the evaporator. Due to cut in exergy loss, exergy efficiency is improved overall from 29.83% (for basic ORC) to 32.6%, 32.78%, and 33.82% for the improved ORC systems for (b), (c) and (d) individually. Besides that, cut in exergy loss leads to improve in the DTP, from 69.7%, 73.1%, 73.9% and 75.34% for ORC (a), (b), (c) and (d), respectively.

Among these four cycles, the ORC incorporating both the internal heat exchanger and regeneration proved the best cycle, which gives the highest thermal efficiency (22.43%), exergy efficiency (33.82%), and lowest exergy destruction (44.5kW).

The results represent that if the evaporator pressure increases, the thermal efficiencies, as well as exergy efficiencies of ORCs also increase and the overall loss of system decreases because of the reduction in the temperature difference between the temperature of hot gas stream getting into the evaporator and the evaporator temperature itself. Therefore, the used exergy and in addition the exergy efficiency are enhanced.

NOMENCLATURE

P	Pressure (kPa)
T	Temperature (K)
ORC	Organic Rankine cycle
H	Enthalpy (kJ/kg)
IHX	Internal heat exchanger
h	Specific enthalpy (kJ/kg)
Q	Required heat
FWH	Feed water heater
E	Exergy (kJ)
m	Mass flow rate (kg/s)
X	Mass flow into feed-water
R	Specific gas constant (kJ/kJ K)
W	Work (kJ)
s	Specific entropy (kJ/kg K)
ϕ	Exergy loss
β	Influence coefficient
Ψ	Specific exergy (kJ/kg)
η	Efficiency
DTP	Degree of thermodynamics perfection (α)

REFERENCES

- [1] Zhang H., Guan H., Ding Y., and Liu C., 2018. Energy analysis of Organic Rankine Cycle (ORC) for waste heat power generation. *Journal of Cleaner Production* 183: 1207-1215.
- [2] Saadat-Targhi M. and S. Khanmohammad. 2019. Energy and exergy analysis and multi-criteria optimization of an integrated city gate station with organic Rankine flash cycle and thermoelectric generator. *Applied Thermal Engineering* 149: 312–324.
- [3] Feng Y., Hung T., He Y., Wang Q., Wang S., Li B., Lin J., and Zhang W., 2017. Operation characteristic and performance comparison of organic Rankine cycle (ORC) for low-grade waste heat using R245fa, R123, and their mixtures. *Energy Conversion and Management* 144: 153–163.
- [4] Kong R., Deethayat T., Asanakham A., Vorayos N., and Kiatsiriroat T., 2019. Thermodynamic performance analysis of an R245fa organic Rankine cycle (ORC) with different kinds of heat sources at evaporator. *Case Studies in Thermal Engineering* 13: 100385.
- [5] Wei F., Senchuang G., and Zhonghe H., 2019. Economic analysis of organic Rankine cycle (orc) and organic Rankine cycle with an internal heat exchanger (IORC) based on industrial waste heat source constraint. *Energy Procedia* 158: 2403–2408.
- [6] Rayegan R. and Y. Tao. 2011. A procedure to select working fluids for solar organic Rankine cycles (ORCs). *Renewable Energy* 36(2): 659–70.
- [7] Quoilin S., 2011. Sustainable energy conversion through the use of organic Rankine cycles for waste heat recovery and solar applications. *Ph.D. thesis*. Belgium: University of Liège, Wallonia, Belgium.
- [8] Braimakis K., Thimo A., and Karellas S., 2017. Techno-economic analysis and comparison of a solar-based biomass ORC-VCC system and a PV heat pump for domestic trigeneration. *Journal of Energy Engineering* 143(2): 04016048.
- [9] Quoilin S., Broek M.V.D., Declaye S., Dewallef P., and Lemort V., 2013. Techno-economic survey of organic Rankine cycle (ORC) systems. *Renewable and Sustainable Energy Reviews* 22: 168–86.
- [10] Astolfi M., Romano M.C., Bombarda P., and Macchi E., 2014. Binary ORC (Organic Rankine Cycles) power plants for the exploitation of medium–low-temperature geothermal sources – Part B: techno-economic optimization. *Energy* 66: 435–46.
- [11] Shokati N., Ranjbar F., and Yari M., 2015. Exergoeconomic analysis and optimization of basic, dual-pressure and dual-fluid ORCs and Kalina geothermal power plants: a comparative study. *Renewable Energy* 83: 527–42.
- [12] Braimakis K., Preißinger M., Brüggemann D., Karellas S., and Panopoulos K., 2015. Low-grade waste heat recovery with subcritical and supercritical organic Rankine cycle based on natural refrigerants and their binary mixtures. *Energy* 88: 80–92.
- [13] Mago P.J., Chamra L.M., and Somayaji C., 2006. Performance analysis of different working fluids for use in organic Rankine cycles. *Proc. IMechE, Part A: J. Power and Energy* 221: 255-264.
- [14] Roy J.P. and A. Misra. 2012. Parametric optimization and performance analysis of a regenerative organic Rankine cycle using R-123 for waste heat recovery. *Energy* 39: 227-235.

- [15] Xi H., Li M.-J., Xu C., and He Y.-L., 2013. Parametric optimization of regenerative organic Rankine cycle (ORC) for low-grade waste heat recovery using a genetic algorithm. *Energy* 58: 473-482.
- [16] Hung T.-Z., 2001. Waste heat recovery of organic Rankine cycle using dry fluids. *Energy Conversion and Management* 42: 539-553.
- [17] Shu G., Liu L., Tian H., Wei H., and Yu G., 2014. Parametric and working fluid analysis of a dual-loop organic Rankine cycle (DORC) used in engine waste heat recovery. *Applied Energy* 113: 1188-1198.
- [18] Long R., Bao Y., Huang X., and Liu W., 2014. Exergy analysis and working fluid selection of organic Rankine cycle for low grade waste heat recovery. *Energy* 73: 475-83.
- [19] Quoilin S., Declaye S., Tchanche B.F., and Lemort V., 2011. Thermo-economic optimization of waste heat recovery organic Rankine cycles. *Applied Thermal Engineering* 31(14): 2885-93.
- [20] Wei D., Lu X., Lu Z., and Gu J., 2008. Dynamic modeling and simulation of an organic Rankine cycle (ORC) system for waste heat recovery. *Applied Thermal Engineering* 28: 1216-1224.
- [21] Liu B.T., Chien K., and Wang C., 2004. Effect of working fluids on organic Rankine cycle for waste heat recovery. *Energy* 29: 1207-17.
- [22] Wang H.T., Wang H., Ge Z., and Leng T.T., 2011. Optimization of the low-temperature geothermal heat powered organic Rankine cycle. *Ind. Heat.* 3: 007
- [23] Sun J. and W. Li. 2011. Operation optimization of an organic Rankine cycle (ORC) heat recovery power plant. *Applied Thermal Engineering* 31: 2032-2041.
- [24] Huan X., Ming-Jia L., Chao X., and Ya-Ling H., 2013. Parametric optimization of regenerative organic Rankine cycle (ORC) for low-grade waste heat recovery using genetic algorithm. *Energy* 58: 473-482.
- [25] Imran M., Park B.S., Kim H.j., Lee D.H., Usman M., and Heo M., 2014. Thermo-economic optimization of Regenerative Organic Rankine Cycle for waste heat recovery applications. *Energy Conversion and Management* 87: 107-118.
- [26] Mago P.J., 2008. An examination of regenerative organic Rankine cycle using dry fluids. *Applied Thermal Engineering* 28: 998-1007.
- [27] Li G., 2016. Organic Rankine cycle performance evaluation and thermoeconomic assessment with various applications part I: energy and exergy performance evaluation. *Renewable and Sustainable Energy Reviews* 53: 477-499.
- [28] Saleh B., Koglbauer G., Wendland M., and Fischer J., 2007. Working fluids for low-temperature organic Rankine cycles. *Energy* 32 (7): 1210-1221.
- [29] Uusitalo A., Honkatukia J., Turunen-Saaresti T., and Larjola J., 2014. A thermodynamic analysis of waste heat recovery from reciprocating engine power plants by means of Organic Rankine Cycle. *Applied Thermal Engineering* 70 (1): 33-41.
- [30] Dai Y.P., 2009. Exergy analysis, parametric analysis, and optimization for a novel combined power and ejector refrigeration cycle. *Applied Thermal Engineering* 29: 1983-1990.
- [31] Regulagadda P., Dincer I., and Naterer G.F., 2010. Exergy analysis of a thermal power plant with measured boiler and turbine losses. *Applied Thermal Engineering* 30: 970-976.
- [32] Aljundi I.H., 2009. Energy and exergy analysis of a steam power plant in Jordan. *Applied Thermal Engineering* 29: 324-328.
- [33] Gutiérrez S., 2013. Energy and exergy assessments of a lime shaft kiln. *Applied Thermal Engineering* 51: 273-280.
- [34] Desai N.B. and S. Bandyopadhyay. 2009. Process integration of organic Rankine cycle. *Energy* 34, 1674-1686.
- [35] Mago P.J., 2008. An examination of exergy destruction in organic Rankine cycles. *International Journal of Energy Research* 32: 926-938.
- [36] Arslan O. and O. Yetik. 2011. ANN-based optimization of supercritical ORC-Binary geothermal power plant: Simav case study. *Applied Thermal Engineering* 31: 3922-3928.
- [37] Badr, O., Ocallaghan, P.W., and Probert S.D., 1990. Rankine-cycle systems for harnessing power from low-grade energy-Sources. *Applied Engineering* 36: 263-292.
- [38] Gu W., Weng Y., Wang Y., and Zheng B., 2009. Theoretical and experimental investigation of an Organic Rankine Cycle for a waste heat recovery system. Part A: *Journal of Power and Energy* 223: 523-533.
- [39] Garg P.D., Dehiya S., Barasiya A., Rahangdale A., and Kumawat V.S., 2013. Exergy and efficiency analysis of combined cycle power plant. *International Journal of Scientific & Engineering Research* 4(12), ISSN 2229-5518.
- [40] Coplan C.C., 2005. Exergy analysis of combined cycle cooperation systems. *M.S. thesis*. Middle East Technical University, Ankara, Turkey.
- [41] Bejan A. 2002. Fundamentals of exergy analysis, entropy generation minimization and the generation of flow architecture. *International Journal of Energy Research* 26: 545-565.